

---

STATUTORY INSTRUMENTS

---

**2002 No. 1093**

**ATOMIC ENERGY AND  
RADIOACTIVE SUBSTANCES**

**The Radioactive Material (Road Transport) Regulations 2002**

<i>Made</i>	- - - -	<i>16th May 2002</i>
<i>Laid before Parliament</i>		<i>17th May 2002</i>
<i>Coming into force</i>	- -	<i>7th June 2002</i>

The Secretary of State for Transport, Local Government and the Regions, in exercise of the powers conferred upon him by sections 2(1), (2), and (3) of the Radioactive Material (Road Transport) Act 1991<sup>(1)</sup> and of all other powers enabling him in that behalf, hereby make the following Regulations:

—

**PART I**

**CITATION, COMMENCEMENT AND APPLICATION**

**Citation and commencement**

1. These Regulations may be cited as the Radioactive Material (Road Transport) Regulations 2002 and shall come into force on 1<sup>st</sup> May 2002.

**Interpretation etc**

2.—(1) These Regulations give effect to an international agreement on the provision of an acceptable level of control of the radiation, criticality and thermal hazards to persons, property and the environment associated with the transport of radioactive material comprised in the Regulations for the Safe Transport of Radioactive Material (1996 Edition (Revised)) published by the International Atomic Energy Authority (“IAEA 1996”)<sup>(2)</sup> and as adapted by the European Agreement concerning the international carriage of dangerous goods by road (“ADR”)<sup>(3)</sup> with any

---

(1) 1991 c. 27 as amended by 2002 c. 1092

(2) No. TS-R-1 (ST-1, Revised) (ISBN 92-0-100500-8).

(3) 2001 (ISBN 92-1-139069-9).

amendments up to 1<sup>st</sup> July 2001, and by Council Directive 96/29/EURATOM(4) and Commission Directive 2001/7/EC(5).

(2) In these Regulations—

“1996 Regulations” means the Radioactive Material (Road Transport) (Great Britain) Regulations 1996(6);

“A<sub>1</sub>” means the activity value of special form radioactive material specified in Table 1 in Schedule 1 or calculated in accordance with regulation 29;

“A<sub>2</sub>” means the activity value of radioactive material (other than special form radioactive material) specified in Table 1 in Schedule 1 or calculated in accordance with regulation 29;

“accident conditions of transport” means conditions of transport involving more than minor mishap;

“ADR journey” has the meaning given in regulation 4(3);

“the Act” means the Radioactive Material (Road Transport) Act 1991(7);

“carrier” means any person (including a government) undertaking the transport of radioactive material and includes carriers for hire or reward and on their own account whether under contract or not;

“competent authority” has the meaning given in regulation 14(2);

“compliance assurance” means a systematic programme of measures applied by the Secretary of State aimed at ensuring that the provisions of these Regulations are met in practice and which is more fully described in regulation 18;

“confinement system” means the assembly of fissile material and packaging components specified by the designer and agreed by the competent authority as intended to preserve criticality safety;

“consignee” means any person (including a government) that receives a consignment;

“consignment” means any package, or load of radioactive material, presented by a consignor for transport;

“consignor” means any person (including a government) that prepares a consignment for transport and is named as consignor in the transport documents, or a freight forwarder acting as agent for such a person;

“containment system” means the assembly of components of the packaging specified by the designer as intended to retain the radioactive material during transport;

“contamination” means the presence of a radioactive substance on a surface in quantities in excess of 0.4 Bq/cm<sup>2</sup> for beta and gamma emitters and low toxicity alpha emitters or in excess of 0.04 Bq/cm<sup>2</sup> for all other alpha emitters; “non-fixed contamination” means contamination that can be removed from a surface during routine conditions of transport and “fixed contamination” means contamination other than non-fixed contamination;

“contracting party country” has the meaning given in regulation 4(8);

“conveyance”, in relation to road transport, means any mechanically propelled vehicle (including an articulated vehicle) intended or adapted for use on roads and, for the purposes of these Regulations, each trailer or semi-trailer forming part of a larger vehicle shall be treated as a separate conveyance;

(4) O.J. L159, 29.6.96, p.1.

(5) O.J. L30, 1.2.01, p.43.

(6) S.I. 1996/1350.

(7) 1991 c. 27 as amended as respects section 1(1)(a) by the Radioactive Material (Road Transport) (Great Britain) (Definition of Radioactive Material) Order 2002 1092.

“Criticality Safety Index” (or “CSI”) assigned to a package, overpack or freight container containing fissile material, means a number that is used to provide control over the accumulation of packages, overpacks or freight containers containing fissile material and is determined in accordance with regulation 45;

“the Dangerous Goods Recommendations” means the eleventh revised edition of “The United Nations Recommendations on the Transport of Dangerous Goods” prepared by the United Nations Committee of Experts on the Transport of Dangerous Goods as published by HMSO;

“depleted uranium” means uranium containing a lesser mass percentage of uranium-235 than in natural uranium;

“design” means the description of special form radioactive material, low dispersible radioactive material, package or packaging which enables that item to be fully identified; the description may include specifications, engineering drawings, reports demonstrating compliance with regulatory requirements and other relevant documentation;

“driver” means the driver of any conveyance;

“enriched uranium” means uranium containing a greater mass percentage of uranium-235 than in natural uranium;

“excepted package” means a package meeting the requirements of Part V of Schedule 8 and to which the controls set out in regulations 41 and 42 apply;

“exclusive use” has the meaning given in regulation 20(2);

“fissile material” means uranium-233, uranium-235, plutonium-239, plutonium-241 (or any combination thereof) but does not include unirradiated natural uranium, unirradiated depleted uranium, or natural uranium or depleted uranium, either of which has been irradiated in thermal reactors only;

“fissile package” means a package meeting the requirements of paragraphs 4 to 10 of Part XIV of Schedule 8;

“freight container” means an article of transport equipment designed to facilitate the transport of goods (either packaged or unpackaged) by one or more modes of transport without intermediate reloading, which is of a permanent enclosed character, rigid and strong enough for repeated use, and fitted with devices facilitating its handling particularly in transfer between conveyances and from one mode of transport to another; and a “small freight container” is a freight container that has either an overall outer dimension of less than 1.5m or an internal volume of not more than 3m<sup>3</sup> and any other freight container is a “large freight container”;

“goods compartment” means a part of a conveyance intended or adapted for the transport of goods or burden;

“Great Britain journey” has the meaning given in regulation 4(2);

“industrial package” means a package, being either—

- (a) an industrial package of Type 1 (Type IP-1) meeting the requirements of Part VI of Schedule 8;
- (b) an industrial package of Type 2 (Type IP-2) meeting the requirements of Part VII of Schedule 8;
- (c) an industrial package of Type 3 (Type IP-3) meeting the requirements of Part VIII of Schedule 8.

“intermediate bulk container (IBC)” means a portable packaging that—

- (a) has a capacity of not more than 3m<sup>3</sup>;
- (b) is designed for mechanical handling;

- (c) is resistant to the stresses produced in handling and transport (as determined by performance tests); and
- (d) is designed to conform to the standards in the chapter on Recommendations on Intermediate Bulk Containers (IBCs) of the Dangerous Goods Recommendations;

“the ISO classification document” means the International Organization for Standardization document, “Sealed radioactive sources – Classification” published by the British Standards Institution (BSI) and HMSO (Reference No. ISO 2919: 1980 (E));

“the ISO freight containers document” means the International Organization for Standardization document, “Series 1 Freight Containers – Specifications and Testing – Part 1: General Cargo Containers” published by the BSI and HMSO (Reference No. ISO 1496:1-1990(E));

“the ISO leak test document” means the International Organization for Standardization document, “Radiation Protection – Sealed Radioactive Sources – Leak Test Methods” published by the BSI and HMSO (Reference No. ISO 9978:1992 (E));

“low dispersible radioactive material” means either a solid radioactive material or a solid radioactive material in a sealed capsule that has limited dispersibility and is not in powder form;

“low specific activity material” (or “LSA material”) means radioactive material that by its nature has a limited specific activity or for which limits of estimated average specific activity (disregarding external shielding materials surrounding the radioactive material) apply, and such material has the following categories—

- (a) “LSA-I” meaning LSA material comprising—
  - (i) ores containing uranium or thorium or mixtures of uranium and thorium (and concentrates of such ores) and other ores containing naturally occurring radionuclides that are intended to be processed for the use of these radionuclides;
  - (ii) solid unirradiated natural uranium or depleted uranium or natural thorium or their solid or liquid compounds or mixtures;
  - (iii) radioactive material for which the  $A_2$  value is unlimited, excluding fissile material in quantities not excepted under paragraph 3 of Part XIV of Schedule 8; or
  - (iv) other radioactive material in which the activity is distributed throughout and the estimated average specific activity does not exceed 30 times the values for activity concentration specified in regulation 28(c) and or calculated in accordance with regulation 29, excluding fissile material in quantities not excepted under paragraph 3 of Part XIV of Schedule 8;
- (b) “LSA-II” meaning LSA material comprising—
  - (i) water with tritium concentration up to 0.8 TBq/L; or
  - (ii) other material in which the activity is distributed throughout and the estimated average specific activity does not exceed  $10^{-4}$   $A_2/g$  for solids and gases, and  $10^{-5}$   $A_2/g$  for liquids;
- (c) “LSA-III” meaning LSA material comprising solids (such as consolidated wastes and activated materials), excluding powders in which—
  - (i) the radioactive material is distributed throughout a solid or a collection of solid objects, or is essentially uniformly distributed in a solid compact binding agent (such as concrete, bitumen and ceramic.);
  - (ii) the radioactive material is relatively insoluble, or is intrinsically contained in a relatively insoluble matrix and which is of such a nature that if the entire contents of a package containing the material were subjected to the test specified in Part I

of Schedule 8 the activity in the water used in the test would not, at the end of the test, exceed  $0.1 A_2$ ; and

- (iii) the estimated average specific activity of the solid, excluding any shielding material, does not exceed  $2 \times 10^{-3} A_2/g$ ;

“low toxicity alpha emitter” means—

- (a) natural uranium;
- (b) depleted uranium;
- (c) natural thorium;
- (d) uranium-235;
- (e) uranium-238;
- (f) thorium-232;
- (g) thorium-228;
- (h) thorium-230;

when contained in ores or physical and chemical concentrates; or

- (i) alpha emitters with a half-life of less than 10 days;

“maximum normal operating pressure” means the maximum pressure above atmospheric pressure at mean sea level that would develop in the containment system in a period of one year under the conditions of temperature and solar radiation corresponding to environmental conditions during transport, in the absence of venting, external cooling by an ancillary system or operational controls;

“multilateral approval” has the meaning given in regulation 14(1)(a);

“natural uranium” means chemically separated uranium containing the naturally occurring distribution of uranium isotopes;

“naturally occurring distribution of uranium isotopes” means approximately 99.28% uranium-238 and 0.72% uranium-235 by mass, but including a very small mass percentage of uranium-234;

“non-ADR journey” has the meaning given in regulation 4(4);

“normal conditions of transport” means conditions of transport involving minor mishaps;

“the Northern Ireland Regulations” means regulations for the time being in force for Northern Ireland under an Order in Council under paragraph 1(1)(b) of Schedule 1 to the Northern Ireland Act 1974(8) that contains the statement specified in section 8 of the Act;

“overpack” means an enclosure (such as a box or bag) that is used by a single consignor to facilitate as a handling unit a consignment of one or more packages for convenience of handling, stowage and transport;

“package” means the packaging (together with its radioactive contents) as presented for transport and may be of the following types—

- (a) excepted package;
- (b) industrial package Type 1 (Type IP-1);
- (c) industrial package Type 2 (Type IP-2);
- (d) industrial package Type 3 (Type IP-3);
- (e) Type A package;

- (f) Type B(U) package;
- (g) Type B(M) package; or
- (h) Type C package.

“packaging” means the assembly of components necessary to enclose the radioactive contents completely and may be a box, a drum or similar receptacle, or a freight container, tank or intermediate bulk container; in particular, packaging may consist of one or more receptacles, absorbent materials, spacing structures, radiation shielding and service equipment for filling, emptying, venting and pressure relief, and devices for cooling, absorbing mechanical shocks, handling and tie-down and thermal insulation and service devices integral to the package;

“personnel compartment” means a driver’s compartment in a conveyance or a part of a conveyance intended or adapted for the carriage of persons in the conveyance;

“quality assurance programme” means a systematic programme of controls and inspections by any organisation or body involved in the transport of radioactive material that is aimed at providing adequate confidence that the standard of safety prescribed in these Regulations is achieved in practice and is more fully described in regulation 18;

“radiation level” means the corresponding dose rate expressed in mSv per hour;

“radiation protection programme” means the programme to provide adequate consideration of radiation protection measures more fully described in regulation 24;

“radioactive contents” means radioactive material together with any contaminated or activated solids, liquids and gases within the packaging;

“road” means a road within the meaning providing adequate confidence that the standard of safety prescribed in these regulations is achieved in practice and which of section 192(1) of the Road Traffic Act 1988(9);

“routine conditions of transport” means conditions of transport that are incident free;

“shipment” means the specific movement of a consignment from origin to destination where that movement includes transport in Great Britain;

“special arrangement” means those provisions approved by the Secretary of State under which consignments that do not satisfy all the applicable requirements of these Regulations may be transported;

“special form radioactive material” means either an indispersible solid radioactive material or a sealed capsule containing radioactive material that meet the requirements set out in Part II of Schedule 8;

“specific activity” means, in relation to a radionuclide, the activity per unit mass of that nuclide and, in relation to a material, the activity per unit mass or volume of the material in which the radionuclides are essentially uniformly distributed;

“surface contaminated object” or “SCO” means a solid object that is not itself radioactive but which has radioactive material distributed on its surfaces and being one of the following—

- (a) SCO-I, a solid object on which—
  - (i) the non-fixed contamination on the accessible surface averaged over 300 cm<sup>2</sup> (or the area of the surface if less than 300cm<sup>2</sup>) does not exceed 4 Bq/cm<sup>2</sup> for beta and gamma emitters and low toxicity alpha emitters, or 0.4 Bq/cm<sup>2</sup> for all other alpha emitters; and

- (ii) the fixed contamination on the accessible surface, averaged over 300 cm<sup>2</sup> (or the area of the surface if less than 300cm<sup>2</sup>) does not exceed  $4 \times 10^4$  Bq/cm<sup>2</sup> for beta and gamma emitters and low toxicity alpha emitters, or  $4 \times 10^3$  Bq/cm<sup>2</sup> for all other alpha emitters; and
  - (iii) the non-fixed contamination plus the fixed contamination on the inaccessible surface, averaged over 300 cm<sup>2</sup> (or the area of the surface if less than 300 cm<sup>2</sup>) does not exceed  $4 \times 10^4$  Bq/cm<sup>2</sup> for beta and gamma emitters and low toxicity alpha emitters, or  $4 \times 10^3$  Bq/cm<sup>2</sup> for all other alpha emitters;
- (b) SCO-II, a solid object on which either the fixed or non-fixed contamination on the surface exceeds the applicable limits specified for SCO-I in (a) above and on which—
- (i) the non-fixed contamination on the accessible surface averaged over 300 cm<sup>2</sup> (or the area of the surface if less than 300 cm<sup>2</sup>) does not exceed 400 Bq/cm<sup>2</sup> for beta and gamma emitters and low toxicity alpha emitters, or 40 Bq/cm<sup>2</sup> for all other alpha emitters; and
  - (ii) the fixed contamination on the accessible surface, averaged over 300 cm<sup>2</sup> (or the area of the surface if less than 300 cm<sup>2</sup>) does not exceed  $8 \times 10^5$  Bq/cm<sup>2</sup> for beta and gamma emitters and low toxicity alpha emitters, or  $8 \times 10^4$  Bq/cm<sup>2</sup> for all other alpha emitters; and
  - (iii) the non-fixed contamination plus the fixed contamination on the inaccessible surface averaged over 300 cm<sup>2</sup> (or the area of the surface if less than 300 cm<sup>2</sup>) does not exceed  $8 \times 10^5$  Bq/cm<sup>2</sup> for beta and gamma emitters and low toxicity alpha emitters, or  $8 \times 10^4$  Bq/cm<sup>2</sup> for all other alpha emitters;

“tank” means a portable tank, a road tank vehicle or a receptacle and may also mean a tank container, each of which has a capacity of not less than 450 litres to contain liquids, powders, granules, slurries or solids which are loaded as gas or liquid and subsequently solidified, and not less than 1000 litres to contain gases; and a “tank container” means a vessel which is capable of being carried on land or on sea and of being loaded and discharged without the need of removal of its structural equipment, possessing stabilising members and tie-down attachments external to the shell, and capable of being lifted when full;

“Transport Index (TI)” means a number that is used to provide control over radiation exposure and is determined in accordance with regulation 44 and assigned to a package, overpack, or freight container, or to unpackaged LSA-I or SCO-I;

“transport of a consignment” has the meaning given in regulation 4(5);

“unilateral approval” has the meaning given in regulation 14(1)(b);

“unirradiated thorium” means thorium containing not more than 10<sup>-7</sup> g of uranium-233 per gram of thorium-232;

“unirradiated uranium” means uranium containing not more than 2 kBq of plutonium per gram of uranium-235, not more than 9 MBq of fission products per gram of uranium-235 and not more than 5mg of uranium-236 per gram of uranium-235;

(3) Unless the context otherwise requires, any other expressions used in these Regulations that are also used in IAEA 1996 or ADR have the meaning given to them in those Regulations or in that Agreement.

(4) In these Regulations, unless the context otherwise requires, any reference to—

- (a) a numbered regulation or a numbered Schedule is a reference to the regulation or Schedule bearing that number in these Regulations;

- (b) a numbered paragraph is a reference to the paragraph bearing that number in the regulation or Schedule in which the reference appears; and
- (c) a Part is a reference to a Part in these Regulations.

### **Continued applicability of other Regulations**

3. Radioactive material that is also to be transported by any other mode of transport must meet the requirements of the Regulations that are applicable to that mode of transport.

### **Scope of Regulations**

4.—(1) Subject to regulation 5 (non-application of regulations), these Regulations apply to the transport of a consignment—

- (a) that is performed by a conveyance;
- (b) where the journey is commenced after these Regulations come into force;
- (c) where the journey involved is by road; and
- (d) where the journey is either
  - (i) a Great Britain journey,
  - (ii) an ADR journey, or
  - (iii) a non-ADR journey.

(2) A “Great Britain journey” is one that takes place entirely within Great Britain.

(3) An “ADR journey” is one where the entire journey takes place only in Great Britain and in the territory of a contracting party country.

(4) A “non-ADR journey” is one where any stage of the journey takes place in Great Britain but any other stage of the journey takes place in the territory of a country that is not a contracting party country.

(5) The “transport of a consignment” means the specific movement of a consignment from origin to destination and includes

- (a) any stops necessitated by transport conditions;
- (b) any period spent by the consignment in the vehicle by reason of traffic conditions before, during or after movement of the consignment;
- (c) any intermediate temporary storage of the consignment in order to change either the mode or means of transport (but only where the transport documents showing the place of dispatch and the place of reception are presented on request and the consignment is not opened during the storage otherwise than for checking by a competent authority); and
- (d) all operations and conditions associated with and involved in the movement of that consignment, including—
  - (i) the design, manufacture and maintenance and repair of packaging,
  - (ii) the preparation, consigning, loading, carriage (including in-transit storage), unloading and receipt at the final destination of loads of radioactive material and packages,
  - (iii) the routine, normal and accident conditions of transport by road encountered in carriage and in storage during transit, and
  - (iv) the transport by road that is incidental to the use of the radioactive material.

(6) “Performed by a conveyance” includes a shipment that involves several different conveyances.



- (7) “Journey” includes a journey—
- (a) that is performed in stages by different modes of transport (carriage by sea, rail, inland waterway or air),
  - (b) that is performed by one carrier or by successive carriers or under a single contract of carriage or a series of contracts of carriage, or
  - (c) where a section of it is subject to other international rules.
- (8) “contracting party country” means a country that, at the time the relevant journey is commenced, is a party to ADR.

### **Non-application of Regulations**

- 5.—(1) These Regulations do not apply to or in relation to—
- (a) radioactive material that is an integral part of the means of transport;
  - (b) radioactive material moved within an establishment that is subject to appropriate safety regulations in force there and where the movement does not involve the use of public roads;
  - (c) radioactive material implanted into the body of a person (whether alive or dead) or of a live animal for diagnosis or treatment;
  - (d) radioactive material in consumer products if those products have been approved by the relevant regulatory authority and have then been sold to a consumer;
  - (e) natural material and ores containing naturally occurring radionuclides that are not intended to be processed for use of those radionuclides if, but only if, the activity concentration of such material or ores does not exceed 10 times the values specified in respect of exempt material in column (4) of Table 1 in Schedule 1; and
  - (f) radioactive material where
    - (i) the activity concentration does not exceed the value specified in paragraph (c) of regulation 28 (basic radionuclide values), or
    - (ii) the total activity in the consignment does not exceed the value specified in paragraph (d) of regulation 28 (basic radionuclide values).
- (2) When the transport of a consignment of radioactive material is made on behalf of a Department of the Government of the United Kingdom or is made in connection with the execution of a contract entered into with any such Department, these Regulations do not apply to the transport of that material if it forms part of an instrument of war or if it is required for research into the development or production of any such instrument (or part of such an instrument) or if it is produced in the course of or in connection with such a development or production.
- (3) When the transport of a consignment of radioactive material is made on behalf of a visiting force or is made in connection with the execution of a contract made with any such force, these Regulations do not apply to the transport of that material if it is, or forms part of, an instrument of war; a “visiting force” is any such body, contingent or detachment of the forces of any State to which the provisions of the Visiting Forces Act 1952(10) apply by virtue of section 1(1)(a) or section 1(1)(b), and any order in Council made under section 1(2) of that Act.
- (4) These Regulations do not apply to, or in relation to, the transport of a consignment—
- (a) undertaken by, or under the supervision of, the emergency services (including by breakdown vehicles carrying vehicles that have been involved in accidents or have broken down and which contain radioactive material);

---

(10) 1952 c. 67.

- (b) in an emergency intended to save human lives or to protect the environment, provided that all measures are taken to ensure that such transport is carried out in complete safety;
- (c) where the journey involved is an ADR journey and the transport is the subject of a bilateral or multilateral special agreement to which the United Kingdom is a signatory made under the terms of paragraph 3 of article 4 of ADR, to the extent that is necessary to meet the terms of that special agreement; or
- (d) where the transport conforms with the terms of any derogations approved under article 6(9) and (10) of Council Directive 94/55/EC(11), to the extent that is necessary to meet the terms of that derogation.

### **Derogations: maritime and air transport**

6.—(1) Subject to paragraph (2), where a package does not entirely meet the requirements of these Regulations but it is in conformity with either the International Maritime Dangerous Goods Code (“the IMDG Code”)(12) or the Technical Instructions for the safe Transport of Dangerous Goods by Air (“the ICAO Technical Instructions”)(13), that package shall be accepted for carriage where the journey is performed in stages by different modes of transport (including maritime or air carriage) if—

- (a) the package (not being marked or labelled in accordance with regulation 48, (responsibilities of consignors)) does bear markings and danger labels in accordance with the requirements of either the IMDG Code or the ICAO Technical Instructions;
- (b) where there is mixed packing within the package, the requirements of the IMDG Code or the ICAO Technical Instructions with respect to mixed packing are complied with;
- (c) for a package involved in transport including maritime carriage, the package (not being marked and labelled in accordance with regulation 48, (responsibilities of consignors)) is marked and labelled in accordance with Chapter 5.3 of the IMDG Code;
- (d) the transport document in respect of the package includes the statement: “Carriage in accordance with 1.1.4.2 of ADR”;
- (e) where in the transport of a freight container the stage of carriage by sea is preceded by another mode of transport, a container packing certificate conforming to section 5.4.2 of the IMDG Code is provided with the transport document; and
- (f) where the vehicle involved is placarded as required by paragraph 30 of Schedule 6.

(2) The derogation allowed under paragraph (1) does not apply (and accordingly, these Regulations do apply) to a package containing goods that, although considered as non-radioactive material according to the applicable requirements of the IMDG Code or the ICAO Technical Instructions, are classified as radioactive material according to these Regulations.

### **Relationship of Regulations to other safety controls**

7.—(1) Nothing in these Regulations is to be taken as specifying, or as being a substitution for, controls (including those concerned with the planning of routes or physical safety) which apply to the transport of radioactive material for reasons other than of radiological safety and, accordingly, such controls—

- (a) must still take radiological and non-radiological hazards into account, but

(11) O.J. No. 319, 12.12.94, p.7.

(12) Implementing Chapter VII, Part A, of the International Convention for the Safety of Life at Sea, 1974 (SOLAS Convention), published by the International Maritime Organisation (IMO), London.

(13) Complementing Annex 18 to the Chicago Convention on International Civil Aviation (Chicago 1944), published by the International Civil Aviation Organisation (ICAO) in Montreal.

(b) shall not be taken as detracting from any of the standards of safety provided for in these Regulations.

(2) For the avoidance of any doubt, in matters—

(a) involving the subsidiary risks arising from radioactive material, and

(b) relating to the transport of radioactive material with other dangerous goods,

the relevant provisions governing the transport of dangerous goods contained in or under the Health and Safety at Work Act(9)(14) remain applicable in addition to the provisions of these Regulations.

### **Revocation of 1996 Regulations**

8. The 1996 Regulations shall be revoked and, subject to Part II, shall cease to have effect in relation to the transport of radioactive material by road commenced on or after the date these Regulations come into force.

## **PART II**

### **SAVINGS AND TRANSITORY PROVISIONS FOR CERTAIN MATTERS UNDER EARLIER INTERNATIONAL REGULATIONS**

#### **General**

9.—(1) In this Part—

“IAEA 1973” means the 1973 or the 1973 (As Amended) Editions of the Regulations for the Safe Transport of Radioactive Material published by The International Atomic Energy Agency, Vienna, (1973 Safety Series No. 6 and 1979 Safety Series No. 6); and

“IAEA 1985” means the 1985 or the 1985 (As Amended 1990) Editions of the Regulations for the Safe Transport of Radioactive Material published by The International Atomic Energy Agency, Vienna, (1990 Safety Series No. 6 (as amended 1990)).

#### **Packages not requiring competent authority approval of design under IAEA 1985**

10.—(1) This regulation has effect in relation to the following types of packages—

(a) Excepted packages;

(b) Industrial packages of Type IP-1;

(c) Industrial Packages of Type IP-2;

(d) Industrial Packages of Type IP-3; and

(e) Type A packages.

(2) A package within paragraph (1) that did not require approval of the package design by a competent authority and which meets the requirements of IAEA 1985 may continue to be used for the transport of radioactive material if, in relation to that package—

(a) all the requirements of the quality assurance programme set out in regulation 18 (quality and compliance assurance programmes; etc) are met; and

(b) the activity limits and material restrictions contained in Part V (activity limits and material restrictions) are fulfilled.

(3) Any modification to the packaging must be made in accordance with, and meet all the requirements of, these Regulations, unless—

- (a) the modification is made in order to, and does, improve the safety of the packaging,
- (b) the packaging is manufactured before 31 December 2003, and
- (c) the modification is made in accordance with, and meets all the requirements of, IAEA 1985.

(4) A package within paragraph (2) may be prepared for the transport of radioactive material at any time before 31 December 2003 in accordance with the requirements of IAEA 1985, but on or after 1 January 2004 all such packages must be prepared for transport in accordance with these Regulations.

### **Packages approved under IAEA 1973**

**11.**—(1) This regulation has effect in relation to packagings that have been manufactured to a package design approved by a competent authority in accordance with IAEA 1973.

(2) Such packagings of which the construction began before the 1<sup>st</sup> January 1996 may continue to be used for the transport of radioactive material if, in relation to that packaging—

- (a) the package design has received multilateral approval;
- (b) all the applicable requirements of the quality assurance programme set out in regulation 18 (quality and compliance assurance programmes etc) are met;
- (c) the activity limits and material restrictions contained in Part V (activity limits and material restrictions) are fulfilled.

(3) For the purposes of—

- (a) paragraph (1), an approval certificate that a package design meets the requirements of IAEA 1973 shall be in the form issued by a competent authority certifying that the design meets the requirements of IAEA 1973, irrespective of any period of limitation on the certificate, and
- (b) paragraph (2)(a), an approval certificate that a package design meets the requirements of IAEA 1973 shall be in the form issued by the Secretary of State certifying that the design meets the requirements of IAEA 1973.

(4) If any changes are made to the design of a packaging or in the nature or quantity of the authorised radioactive contents of a packaging that, in the opinion of the Secretary of State, would significantly affect safety, those changes must meet all the requirements of these Regulations.

(5) Before use, the packaging must be marked with a serial number in accordance with paragraph 5 of Schedule 6.

### **Packages approved under IAEA 1985**

**12.**—(1) This regulation has effect in relation to packagings that have been manufactured to a package design approved by a competent authority in accordance with IAEA 1985.

(2) Such packaging may continue to be used for the transport of radioactive material until 31st December 2003 if in relation to that packaging—

- (a) all the requirements of the quality and compliance assurance programme etc set out in regulation 18 (quality and compliance assurance programme etc) are met;
- (b) the activity limits and the material restrictions contained in Part V (activity limits and material restrictions) are fulfilled.

(3) For the purposes of paragraph (1), an approval certificate that a package design meets the requirements of IAEA 1985 shall be in the form issued by a competent authority certifying that the design meets the requirements of IAEA 1985 irrespective of any period of limitation on the certificate.

(4) The packaging may continue to be used in the transport of radioactive material on or after 1st January 2004 if, in addition to the conditions mentioned in paragraph (2) being satisfied in relation to that package, there has been multilateral approval of the package design.

(5) For the purposes of paragraph (4), an approval certificate that a package design meets the requirements of IAEA 1985 shall be in the form issued by the Secretary of State certifying that the design meets the requirements of IAEA 1985.

(6) If any changes are made to the design of a packaging or in the nature or quantity of the authorised radioactive contents of a packaging that, in the opinion of the Secretary of State, would significantly affect safety, those changes must meet all the requirements of these Regulations.

(7) The manufacture of all packaging commencing on or after 1 January 2007 must meet the requirement of these Regulations in full.

(8) For the purpose of paragraph (7), the manufacture of a packaging shall not be regarded as having commenced on or after 1st January 2007 if all the components which that packaging needs in order to completely enclose the radioactive material to be contained in it have already been delivered to the place of manufacture before that date.

### **Special form radioactive material approved under IAEA 1973 or IAEA 1985**

13.—(1) This regulation has effect in relation to any special form radioactive material that has been manufactured to a design approved by a competent authority in accordance with either IAEA 1973 or IAEA 1985.

(2) Such special form radioactive material may continue to be transported if, in relation to that material, all the applicable requirements of the quality assurance programme set out in regulation 18 (quality and compliance assurance programmes; etc) are met.

(3) All special form radioactive material manufactured on or after 1 January 2004 must meet the requirements of these Regulations in full.

(4) For the purpose of paragraph (3), the manufacture of special form radioactive material shall not be regarded as having commenced on or after 1 January 2004 if all the components which that special form radioactive material needs have already been delivered to the place of manufacture before that date.

## **PART III**

### **GENERAL PROVISIONS RELATING TO THE REGULATION OF TRANSPORT**

#### **Types of regulatory approvals**

14.—(1) The following types of approval are relevant for the purpose of these Regulations, namely—

- (a) multilateral approval, meaning the approval of a design or shipment by the relevant competent authority not only of the country of origin of that design or shipment but also at least of each country through or into (but not over) which the consignment is to be transported;
- (b) unilateral approval, meaning the approval of a design which is required to be given only by the competent authority of the country of origin of that design.

(2) A “competent authority” means such national or international regulatory body or authority of a contracting party country as is designated or otherwise recognised as such for any purposes in connection with IAEA 1996 and, in relation to Great Britain, references in these Regulations to actions or decisions of the Secretary of State shall be taken as being the action or decision of a competent authority.

### **General prohibition**

15.—(1) No person shall—

- (a) undertake the design of any packaging or package,
- (b) operate or maintain any packaging or package, or
- (c) transport, or cause or permit to be transported in any packaging or package any radioactive material,

otherwise than in accordance with the provisions of, and in compliance with the requirements of, these Regulations.

(2) “Requirements” includes any conditions, limitations or restrictions.

(3) There shall be no transport of a consignment into Great Britain from Northern Ireland unless, prior to the commencement of the first section of its journey in Great Britain, the carrier knows (or has reasonable grounds to believe) that the consignment meets the requirements of the Northern Ireland Regulations as to its labelling and transport documents.

### **General duty to exercise reasonable care**

16. Without prejudice to any other regulation, the consignor, carrier and the driver of a consignment must exercise reasonable care to ensure that in the course of the transport of a consignment no injury to health or any damage to property or to the environment is caused.

### **General exception**

17. There is no contravention of or failure to comply with these Regulations by a person who neither knew nor had reasonable grounds for believing that the material was in question was radioactive.

### **Quality and compliance assurance programmes; prohibitions etc**

18.—(1) In order to ensure compliance with these Regulations—

- (a) a programme of quality assurance shall be established in accordance with paragraphs (2) to (5), and
- (b) the powers and procedures set out in paragraphs (6) to (9) shall apply as respects compliance assurance.

(2) As respects the design, manufacture, testing, documentation, carriage, use, maintenance and inspection—

- (a) of all special form radioactive material,
- (b) of all low dispersible radioactive material,
- (c) of all packages and packaging, and
- (d) for transport and in-transit operations,

the user must establish and maintain a quality assurance programme to ensure that the requirements of these Regulations are complied with and provide evidence of the efficacy of such a programme to an inspector upon request.

(3) Where these Regulations require that a design or a shipment be approved by the Secretary of State, no such approval shall be given until the Secretary of State is satisfied as to the adequacy of the quality assurance programme for that design or shipment.

(4) The user, when so requested by an inspector, must—

- (a) provide him with facilities to inspect the package, packaging or material during its construction and use;
- (b) demonstrate to him that the construction methods and materials used for the construction of all packaging, special form radioactive material or low dispersible radioactive material are in accordance with the approved design specifications;
- (c) demonstrate to him that all packagings or special form radioactive material or low dispersible radioactive material manufactured to an approved design are periodically inspected as appropriate and, as necessary, repaired and maintained in good condition so that they continue to comply with all the requirements of these Regulations, even after repeated use; and
- (d) in the case of a design specification that has been fully implemented, produce to him a certificate to that effect.

(5) In paragraphs (2) to (4)

“requirements” includes any conditions, limitations and restrictions;

“design authority” means any person responsible for the design of a package or packaging, special form radioactive material and low dispersible radioactive material; and

“user” includes a consignor, consignee, carrier, owner, freight forwarder, design authority, and any person associated with manufacture, testing, maintenance and inspection of packages, packagings, special form radioactive material and low dispersible radioactive material.

(6) The powers and procedures referred to in paragraph (1)(b) apply as respects—

- (a) the design, manufacture, testing, inspection and maintenance of—
  - (i) packagings,
  - (ii) special form radioactive material,
  - (iii) low dispersible radioactive material,and
- (b) the transport of a consignment.

(7) If it appears to an inspector that any person engaged in—

- (a) any of the operations set out in paragraph (6)(a), or
- (b) the transport of a consignment,

is not, or is not likely to, comply with any of the requirements of these Regulations and that as a result there is a risk of injury to health or damage to property or to the environment, he may as respects that person either—

- (i) impose a prohibition, or
- (ii) serve a notice

in accordance with the following provisions of this regulation.

(8) A prohibition imposed under sub-paragraph (b)(i) of paragraph (7) may apply absolutely or for a specified purpose and either without any limitation or for a specified period and shall come into force as soon as a written notice is handed or sent (by post, facsimile or any electronic means) to the person concerned; and the notice imposing it must—

- (a) state whether the prohibition applies absolutely or for a specified purpose (and if the latter, specifying the purpose); and
  - (b) state whether the prohibition applies without limitation of time or for a specified period.
- (9) In a notice served under sub-paragraph (b)(ii) of paragraph (7), an inspector must—
- (a) give particulars identifying what the non-compliance or likely non-compliance is;
  - (b) state that it is his opinion that such non-compliance or likely non-compliance gives, or could give, rise to a risk of injury to health or damage to property or environment;
  - (c) specify the steps (including any temporary measures that are thought to be appropriate) that are to be taken to remedy or to avert the non-compliance; and
  - (d) stipulate the period within which those steps or measures must be taken.
- (10) “Requirements” in paragraph (7) includes any conditions, limitations and restrictions.
- (11) Any person upon whom either a prohibition is imposed or a notice is served under paragraph (7) must comply with that prohibition or notice.

#### **Transport of consignments under special arrangement**

**19.**—(1) Where, in relation to the transport of a consignment, all or some of the requirements of these Regulations cannot be complied with, the transport of that consignment is prohibited unless undertaken in accordance with an approval given under the following paragraphs.

- (2) In the case of a Great Britain journey, if the Secretary of State is satisfied—
  - (a) that the non-compliance with the requirement is on grounds of impracticability of compliance as respects that consignment, and
  - (b) that a commensurate level of safety to that which would be provided in relation to that consignment by the application of any relevant provision of these Regulations can be provided by alternative means,

he may give an approval for the transport of that consignment.

(3) Application for an approval by the Secretary of State pursuant to paragraph (2) shall be made in accordance with the provisions of regulation 61 (approval of shipments under special arrangement) and may be made in respect of a single consignment or of a planned series of multiple consignments.

(4) The approval by the Secretary of State pursuant to paragraph (2) shall be given by a special arrangement approval certificate which shall set out the conditions under which (and only under which) the transport of that consignment may be made.

#### **Transport of consignments under exclusive use**

**20.**—(1) No person shall transport, or cause to be transported, any consignment under exclusive use unless the radiation level of the consignment is within the limits set out in paragraph 8 of Schedule 7.

(2) “Exclusive use” means the sole use, by a single consignor, of a conveyance or of a large freight container, in respect of which all initial, intermediate and final loading and unloading is carried out in accordance with the directions of the consignor or of the consignee.

#### **Prohibition on persons travelling in vehicles transporting radioactive material**

**21.** No person except the driver and his assistant or assistants may travel in a vehicle transporting packages, overpacks or freight containers bearing category II-YELLOW or III-YELLOW labels.



### **Transport of consignments containing packages not designed in a contracting party country**

**22.**—(1) Before the transport of a consignment that contains a package, the design of which originates in a non-contracting party country and which requires unilateral approval pursuant to these Regulations, is commenced—

- (a) a certificate must have been issued in respect of the package by an authority in that non-contracting party country proving that the package satisfies the technical requirements of ADR; and
- (b) this certificate must have been countersigned by the competent authority of a contracting party country.

(2) In a case where neither the certificate required under paragraph (1) above nor an existing package design approved by a contracting party country is provided, the transport of the consignment may only be commenced if a competent authority of a contracting party country has approved the package design.

### **Categories of packages**

**23.** Packages and overpacks must be assigned to either category I-WHITE, II-YELLOW or III-YELLOW in accordance with the conditions set out in Schedule 11.

## **PART IV**

### **GENERAL PROVISIONS RELATING TO RADIATION PROTECTION, SAFETY PROGRAMMES AND INFORMATION TO THE PUBLIC**

#### **Radiation protection programme**

**24.**—(1) This regulation applies to every carrier, consignor and consignee involved in the transport of a consignment and in this regulation an “employee” of a carrier, consignor or consignee includes any person who is an agent and any other person of whose services that carrier, consignor or consignee makes use in the transport of a consignment.

(2) Every carrier, consignor and consignee must, as respect his employees, establish a radiation protection programme which—

- (a) takes into account the nature and extent of the measures to be taken in respect of the magnitude and likelihood of radiation exposure, and
- (b) adopts a structured and systematic approach (including consideration of the interfaces between road transport and other activities).

(3) A carrier, consignor and consignee will be regarded as meeting his obligations under paragraph (2)(a) if he carries out and adheres to the relevant provisions of Part II (general principles and procedures) of the Ionising Radiations Regulations (1999)(**15**).

(4) Every carrier, consignor and consignee must—

- (a) at suitable intervals (not exceeding 3 years) review and, where necessary, revise the radiation protection programme as respects his employees, such review taking into account any changes that have occurred in the transport of radioactive material to which the programme relates as well as any advances in technical knowledge and any material change to the assessment on which the programme was based;

---

(15) S.I. 1999/3232.

- (b) upon a written request made to him by the secretary of state, make his radiation protection programme, or any revision of it, available to the Secretary of State.

### **Segregation of radioactive material**

**25.**—(1) The obligations upon a carrier, a consignor and a consignee (as the case may be) during the transport of a consignment as regards the segregation of radioactive material are that packages, overpacks, containers and tanks must be segregated from—

- (a) areas where persons (other than those referred to in sub-paragraph (c)) have regular access—
- (i) in accordance with Table XII of Schedule 1; or
  - (ii) by a distance calculated to ensure members of the critical group in that area receive less than 1mSv per year;
- (b) undeveloped photographic film and mailbags, in accordance with Table XIII of Schedule 1;
- (c) workers in regularly occupied working areas, either—
- (i) in accordance with Table XII of Schedule 1; or
  - (ii) by a distance calculated to ensure that workers in that area receive less than 5 mSv per year; and
- (d) other dangerous goods in accordance with regulation 36 (segregation of consignments from other dangerous goods).
- (2) In paragraph (1)—
- “critical group” means a group of members of the public which is reasonably homogeneous with respect to its exposure to a given radiation source and given exposure pathway and is typical of an individual receiving the highest effective dose by a given exposure pathway from the given source; and
- “workers” means any persons who work (whether full time, part-time or temporarily) for an employer and who have recognised rights and duties in relation to occupational radiation protection pursuant to the Ionising Radiations Regulations 1999.

### **Information to the public about health protection measures**

**26.**—(1) Every carrier, consignor and consignee carrying out the transport of a consignment must—

- (a) ensure that any members of the public who are in an area in which, in the opinion of the Secretary of State, they are likely to be affected by a radiological emergency arising from the undertaking of that carrier, consignor or consignee (as the case may be) are supplied, in the appropriate manner approved by the Secretary of State and without their having to request it, with at least the information set out in paragraph (2); and
  - (b) make that information publicly available, which includes endeavouring to enter into an agreement or arrangement with the local authority in the area referred to in sub-paragraph (a) for the dissemination by that authority of the information required to be supplied to members of the public in accordance with that sub-paragraph.
- (2) The following is the information that is to be supplied and made available under this regulation—
- (a) the basic facts about the radioactivity and its effects on persons and on the environment;
  - (b) the various types of radiological emergency possible and their consequences for the general public and the environment;

- (c) the emergency measures envisaged to alert, protect and assist the general public in the event of the occurrence of a radiological emergency;
  - (d) appropriate information on action to be taken by the general public in the event of the occurrence of a radiological emergency; and
  - (e) the appropriate local authority responsible for implementing the emergency measures and action referred to in (c) and (d) above.
- (3) In preparing the information to be supplied and made available under this regulation, the carrier, consignor or consignee shall—
- (a) consult the Secretary of State, but shall remain responsible for the accuracy, completeness and form of the information supplied; and
  - (b) endeavour to enter into an agreement or arrangement with the local authority where his undertaking is situated with respect to the dissemination by that authority of the information to members of the public.
- (4) The information supplied and made available under this regulation must be updated at regular intervals but, in any case, at least every 3 years and whenever significant changes to any of the matters mentioned in paragraph (2) take place; and when information is updated it must be supplied again in accordance with paragraph (2) and made publicly available.
- (5) In this regulation—
- “radiological emergency” has the same meaning as in regulation 66 (interpretation);
  - “undertaking” includes a business and also any activity carried on by a body of persons (whether corporate or incorporate).

### **Emergency response**

**27.** In the event of an accident or incident occurring during the transport of a consignment, the provisions of Part XII (radiological emergencies and intervention arrangements) shall have effect.

## **PART V**

### **ACTIVITY LIMITS AND MATERIAL RESTRICTIONS**

#### **Basic radionuclide values**

**28.** The individual radionuclides set out in column 1 of Table 1 in Schedule 1 are given the basic values specified respectively in columns (2) to (5) of that Table for—

- (a)  $A_1$  in TBq;
- (b)  $A_2$  in TBq;
- (c) activity concentration for exempt material in Bq/g; and
- (d) activity limits for exempt consignments in Bq.

#### **Calculation of basic radionuclide values**

**29.—(1)** If a consignment containing individual radionuclides that are not listed in Table 1 in Schedule 1 is—

- (a) to be involved in a Great Britain journey, the calculation of its basic radionuclide values specified in regulation 28 (basic radionuclide values) must have the approval of the

Secretary of State, but his approval will not be required if the radionuclide values listed in Table 2 in Schedule 1 are used;

(b) to be involved in an ADR journey or in a non-ADR journey, the calculation of its radionuclide values must have multilateral approval.

(2) Where the chemical form of each radionuclide is known the  $A_2$  value related to its solubility class as recommended by the International Commission on Radiological Protection may be used if the chemical forms under normal and accident conditions of transport are taken into consideration.

(3) The calculation of  $A_1$  and  $A_2$  for a radionuclide that is not listed in Table I of Schedule 1 is to be made in accordance with Schedule 2.

(4) For mixtures of radionuclides, the calculation of the basic radionuclide values referred to in regulation 28 (basic radionuclide values) may be determined in accordance with Schedule 3.

(5) For individual radionuclides (or for mixture of radionuclides) for which relevant data are not available, or for unknown radionuclides, the values shown in Table II in Schedule 1 must be used.

### **Content limits for packages**

**30.**—(1) The quantity of radioactive material in a package must not exceed the relevant limits that are specified in paragraph (2).

(2) Every type of package or material set out below must comply with the contents limits that are applicable to it by virtue of the paragraph in Schedule 4 indicated.

Excepted packages	paragraphs 1 and 2
Industrial packages	paragraph 3
Type A packages	paragraph 4
Type B(U) package	paragraph 5
Type B(M) package	paragraph 5
Type C packages	paragraph 5
Packages containing fissile material	paragraph 6
Packages containing uranium hexafluoride	paragraph 7
Special arrangement transport operation	paragraph 8

## **PART VI**

### **REQUIREMENTS AND CONTROLS FOR TRANSPORT**

#### **Requirements to be fulfilled by the consignor before the first shipment**

**31.**—(1) This regulation has effect for the purpose of imposing requirements that a consignor (being the first consignor, who makes the first use of a package for the purpose of undertaking a shipment) must fulfil, or ensure are fulfilled, before making that shipment.

(2) The requirements are—

(a) if the design pressure of the containment system exceeds 35 kPa (gauge), that the containment system of each package conforms to the approved design requirements relating to the capability of that system to maintain its integrity under that pressure;

- (b) the effectiveness of the shielding and containment and (where necessary) the heat transfer characteristics and the effectiveness of the confinement system of each package of Type B(U), Type B(M) and Type C and also each package containing fissile material are within the limits applicable to or specified for the approved design; and
- (c) where, in order to comply with Part XIV of Schedule 8 (which sets out requirements for packages containing fissile material), neutron poisons are specifically included as components of the package, that checks are carried out to confirm the presence and distribution of those neutron poisons.

### **Requirements to be fulfilled by consignor before each shipment**

**32.**—(1) This regulation imposes, in relation to various types of packages containing various kinds of material, the requirements that each consignor must fulfil to use a package for the purpose of undertaking both—

- (a) the first shipment of that package pursuant to regulation 31 (requirements to be fulfilled by the consignor before first shipment); and
  - (b) every shipment of that package thereafter.
- (2) The requirements are—
- (a) that—
    - (i) for any package, all the requirements specified in the relevant provisions of these Regulations have been satisfied;
    - (ii) each Type B(U), Type B(M) and Type C package must be held until equilibrium conditions have been approached closely enough to demonstrate compliance with the requirements for temperature and pressure unless an exemption from these requirements has received unilateral approval; and
    - (iii) for packages containing fissile material, the measurement specified in paragraph 9 of Part XIV of Schedule 8 (which sets out an estimate of the neutron multiplication for the package assessment) and the tests to demonstrate closure of each package as specified in paragraph 6 of Part XIV of Schedule 8 (which sets out the assessment for an individual package in isolation) must be performed where applicable; and
  - (b) that it is ensured—
    - (i) that the lifting attachments not meeting the requirements specified in paragraph 2 of Part IV of Schedule 8 have been removed or otherwise rendered incapable of being used for lifting the package in accordance with paragraph 3 of Part IV of Schedule 8;
    - (ii) that all the requirements specified in the approval certificates for each Type B(U), Type B(M) and Type C package and for each package containing fissile material have been satisfied;
    - (iii) whether by inspection or by appropriate tests (or both), that all closures, valves and other openings of the containment system through which the radioactive contents might escape are properly closed and (where appropriate) sealed in a manner for which the demonstrations of compliance with the requirements specified in paragraph 7 of Part XI, paragraph 1 of Part XII and paragraph 3 of Part XIII of Schedule 8 were made;
    - (iv) for each special form radioactive material, that all the requirements specified in the special form approval certificate and the relevant provisions of these Regulations have been satisfied; and

- (v) for each low dispersible radioactive material, that all the requirements specified in the approval certificate and the relevant provisions of these Regulations have been satisfied.

#### **Transport of other goods in packages**

**33.**—(1) The consignor must ensure that a package does not contain any other items except such articles and documents as are necessary for the use of the radioactive material in the package.

(2) But—

- (a) low specific activity material or
- (b) surface contaminated objects

may be transported with other items.

(3) The transport of—

- (a) such articles and documents as are necessary for the use of the radioactive material in the package or
- (b) low specific activity material with other items, or
- (c) surface contaminated objects with other items,

is allowed if there is no interaction between these items and the packaging or its radioactive contents that would reduce the safety of the package.

#### **Restrictions on the use of tanks etc**

**34.** A tank or an intermediate bulk carrier that has been used for the transport of radioactive material must not be used for the storage or for the transport of other goods unless the tank or container has been decontaminated—

- (a) below the level of  $0.4 \text{ Bq/cm}^2$  for beta and gamma emitters and low toxicity alpha emitters, and
- (b) below the level of  $0.04 \text{ Bq/cm}^2$  for all other alpha emitters.

#### **Transport of other goods with consignments transported under exclusive use**

**35.** The transport of other goods with consignments being transported under exclusive use in accordance with regulation 20 (transport of consignments under exclusive use) is allowed if—

- (a) the arrangements for the transport are controlled solely by the consignor and
- (b) such transport is not prohibited by or under any statute.

#### **Other dangerous properties of contents and the segregation of consignments from other dangerous goods**

**36.**—(2) The carrier must—

- (a) ensure that during transport every consignment is segregated from any other dangerous goods, and
- (b) in the packing, labelling, marking, placarding, storage and transport of a package, take into account, not only radioactive and fissile properties of the contents, but also any other dangerous properties (including explosiveness, flammability, pyrophoricity, chemical toxicity and corrosiveness),

in order to be in compliance with the provisions mentioned in paragraph (2)

- (2) Those provisions are—
  - (a) these Regulations;
  - (b) the relevant regulations for dangerous goods of each of the countries through or into which the consignment will be transported;
  - (c) where applicable, the regulations of the cognisant transport organisation; and
  - (d) as respects paragraph (1)(a), ADR 7.5.2 (mixed loading prohibition).

### **Requirements and controls for contamination and for leaking packages**

**37.**—(1) This regulation and (where appropriate) Part XII (radiological emergencies and intervention arrangements) apply for the purpose of imposing requirements and controls relating to contamination and leaking packages and the measures to be taken in the event of damage or leakage occurring.

- (2) The consignor must ensure that the levels of non-fixed contamination—
  - (a) on the external surfaces of any package, are kept as low as practicable and (under routine conditions of transport) do not exceed—
    - (i) 4 Bq/cm<sup>2</sup> for beta and gamma emitters and low toxicity alpha emitters, and
    - (ii) 0.4 Bq/cm<sup>2</sup> for all other alpha emitters.

these limits being applicable when averaged over any area of 300 cm<sup>2</sup> of any part of the surface;

- (b) on the external and internal surfaces of any overpack, freight container, tank or intermediate bulk container, do not (subject to regulation 40 (exception in cases of certain overpacks, freight containers etc)) exceed the limits specified in sub-paragraph (a) above.
- (3) Whenever it is—
  - (a) evident to the consignor or the carrier that a package is damaged or is leaking, or
  - (b) suspected by the consignor or the carrier that a package may have been damaged or may have leaked,

he must restrict access to that package and must arrange for a qualified person to make an assessment of the extent of the contamination and of the resultant radiation level of the package as soon as possible.

- (4) The scope of the assessment required under paragraph (3) must include—
  - (a) the package;
  - (b) the conveyance;
  - (c) the adjacent loading and unloading areas; and
  - (d) if necessary, all other material which has been carried in or on the conveyance.

(5) When required by the Secretary of State, additional steps approved for the protection of persons, property and the environment must, be taken to overcome and minimise the consequences of any leakage or damage that has arisen.

(6) Any package that has become damaged, or from which any radioactive contents in excess of allowable limits for normal conditions of transport is leaking, may, under the direction of a suitably qualified specialist in radiation protection, be removed to an acceptable interim location under supervision; but any such package must not be forwarded until it has been repaired or reconditioned and it has been decontaminated.

**Checks to be made on conveyances and equipment**

**38.** A conveyance and equipment used routinely for the transport of radioactive material must be periodically checked by the consignor or his agent to determine the level of contamination, the frequency of such checks being related to the likelihood of contamination and the extent to which radioactive material is transported.

**Decontamination**

**39.** Except as provided in regulation 40 (exception in cases of certain overpacks, freight containers etc), the carrier must ensure that any conveyance or equipment (or part thereof)—

- (a) that in the course of the transport of radioactive material has become contaminated above the limits specified in paragraph (2)(a) of regulation 37 (requirements and controls for contamination etc), or
- (b) that shows a radiation level in excess of 5  $\mu\text{Sv/h}$  at the surface,

is decontaminated as soon as possible by a suitably qualified person and is not re-used unless and until—

- (i) the non-fixed contamination does not exceed the limits specified in paragraph (2)(a) of regulation 37 (requirements and controls for contamination etc), and
- (ii) the radiation level resulting from the fixed contamination of the surfaces after decontamination is less than 5  $\mu\text{Sv/h}$  at the surface.

**Exception in cases of certain overpacks, freight containers etc**

**40.** An overpack, freight container, tank, intermediate bulk container or conveyance that is dedicated to the transport of radioactive material under exclusive use is excepted from the requirements of paragraph (2)(b) of regulation 37 (requirements and controls for contamination etc) and regulation 39 (decontamination)—

- (a) with regard to (but only with regard to) its internal surfaces and
- (b) only for so long as it remains under that specific exclusive use.

**Particular requirements and controls applicable in the case of the transport of excepted packages**

**41.—**(1) This regulation has effect for the purpose of applying certain provisions and requirements of this Part and of Part VIII (requirements for radioactive material and for packagings and packages) to excepted packages.

- (2) Only the following provisions apply to excepted packages
  - (a) the requirements specified in paragraphs (3) to (6);
  - (b) the requirements specified in regulation 36 (other dangerous properties of contents and the segregation of consignments from other dangerous goods), paragraphs (2)(a) and (5) of regulation 37 (requirements and controls for contamination and for leaking packages), and regulation 42 (transport of empty packagings);
  - (c) the requirements specified in paragraphs 1 to 3, 17(a), (b), (c), (d) and (f), and 18 to 22 of Schedule 6;
  - (d) the requirements for excepted packages specified in Part V of Schedule 8; and
  - (e) if the excepted package contains fissile material, one of the exceptions provided for in paragraph 3 of Part XIV of Schedule 8.



(3) The radiation level at any point on the external surface of an excepted package must not exceed 5  $\mu\text{Sv/h}$ .

(4) Radioactive material that is enclosed in, or is included as a component part of, an instrument or other manufactured article having activity not exceeding the item and package limits specified in columns 2 and 3 of Table III in Schedule 1, may be transported in an excepted package if (but only if)—

- (a) the radiation level at 10 cm from any point on the external surface of any unpackaged instrument or article does not exceed 0.1 mSv/h;
- (b) each instrument or article (except radioluminescent time-pieces or devices) bears the marking “RADIOACTIVE”; and
- (c) the radioactive material is completely enclosed by non-active components,

and for the purposes of this paragraph, a device that performs the sole function of containing radioactive material is not an instrument or manufactured article.

(5) Radioactive material in form other than as specified in paragraph (4) having activity not exceeding the limit specified in Table III in Schedule 1 (basic radionuclide values), may be transported if (but only if)—

- (a) the package retains its radioactive contents under routine conditions of transport;
  - (b) the package bears the marking “RADIOACTIVE” on an internal surface in such manner that a warning of the presence of radioactive material is visible on opening the package.
- (6) A manufactured article in which the sole radioactive material is unirradiated—
- (a) natural uranium,
  - (b) depleted uranium, or
  - (c) natural thorium,

may be transported as an excepted package if (but only if) the outer surface of the uranium or thorium is enclosed in an inactive sheath made of metal or some other substantial material.

### **Transport of empty packagings**

**42.** An empty packaging that has previously contained radioactive material may be transported as an excepted package if (but only if)—

- (a) it is in a well maintained condition and is securely closed;
- (b) the outer surface of any uranium or thorium in its structure is covered with an inactive sheath made of metal or of some other substantial material;
- (c) the level of internal non-fixed contamination does not exceed 100 times the levels that are specified in paragraph (2)(a) of regulation 37 (requirements and controls for contamination and for leaking packages); and
- (d) any labels that may have been displayed on it in conformity with the labelling requirements of regulation 48 (responsibilities of consignors) are no longer visible.

### **Requirements and controls for the transport of LSA material and SCO in industrial packages or unpackaged**

**43.—**(1) This regulation has effect for the purpose of imposing the requirements for, and the controls with respect to, the transport of LSA material or SCO in a single—

- (a) industrial package Type 1;
- (b) industrial package Type 2; or

(c) industrial package Type 3.

(2) The quantity of the material described in paragraph (1), or (as the case may be) of an object or collection of objects, must be so restricted that the external radiation level at 3 m from the unshielded material or object or collection of objects does not exceed 10 mSv/h.

(3) LSA material and SCO in groups LSA-I and SCO-I may be transported unpackaged under the following conditions—

(a) all unpackaged material (other than ores containing only naturally occurring radionuclides) must be transported in such manner that under routine conditions of transport there will—

(i) be no escape of the radioactive contents from the conveyance, nor

(ii) any loss of shielding;

(b) each conveyance must be under exclusive use (except if it is transporting only SCO-I on which the contamination on the accessible and inaccessible surfaces does not exceed 10 times the applicable level specified in the definition of “contamination” in regulation 2(2)); and

(c) in the case of SCO-I, where it is suspected that non-fixed contamination exists on inaccessible surfaces that exceeds the values specified in (a)(i) of the definition of “SCO” in regulation 2(2), measures must be taken so as to ensure that the radioactive material is not released into the conveyance.

(4) Except as provided in paragraph (3), LSA material and SCO must be packaged in accordance with Table IV in Schedule 1.

(5) The total activity in a conveyance for the carriage of LSA material or SCO in Type IP-1, Type IP-2, Type IP-3 or unpackaged must not exceed the limits specified in Table V of Schedule 1.

#### **Determination of transport index (TI)**

44. The transport index for—

(a) a package,

(b) an overpack,

(c) a freight container, or

(d) unpackaged LSA-I or SCO-I,

shall be the number derived in accordance with the procedure set out in paragraphs 1 and 2 of Schedule 5.

#### **Determination of criticality safety index (CSI)**

45. The criticality safety index for packages containing fissile material shall be determined in accordance with paragraphs 3 and 4 of Schedule 5.

#### **Limits on TI, CSI and radiation levels for packages and overpacks**

46.—(1) Except for consignments under exclusive use—

(a) the TI of any package or overpack must not exceed 10, and

(b) the CSI of any package or overpack must not exceed 50.

(2) Except for packages or overpacks transported under exclusive use by road under the conditions specified in regulation 20 (transport of consignments under exclusive use), the maximum

radiation level at any point on any external surface of a package or overpack must not exceed 2 mSv/h.

(3) The maximum radiation level at any point on the external surface of a package under exclusive use must not exceed 10 mSv/h.

## PART VII

### FURTHER RESPONSIBILITIES OF CONSIGNORS AND CARRIERS

#### Persons for whom consignors and carriers are responsible

47. For the purposes of these Regulations, a consignor or a carrier is responsible for the acts and omissions of—

- (a) his employees, and
- (b) any agents or other persons of whose services he makes use for the performance of the transport of radioactive material,

when such employees, agents or other persons are acting within the scope of their employment then such acts or omissions are considered to be those of the consignor or carrier.

#### Responsibilities of consignors

48. The responsibilities set out below are further responsibilities upon the consignor and are more fully described in the paragraph in Schedule 6 indicated—

Marking	paragraphs 1 to 7
Labelling	paragraphs 8 and 9
Labelling for radioactive contents	paragraph 10
Labelling for criticality safety	paragraphs 11 and 12
Placarding	paragraphs 13 to 16 and 30
Particulars of consignment	paragraph 17
Declaration	paragraphs 18 to 21
Removal or covering of labels	paragraph 22
Information for carriers	paragraphs 23 and 24
Notification of competent authorities	paragraphs 25 to 28
Possession of certificates and instructions	paragraph 29

#### Responsibilities of carriers

49.—(1) The responsibilities set out below are further responsibilities upon the carrier and are more fully described in the paragraph in Schedule 7 indicated—

Segregation of packages etc during transport and storage in transit	paragraphs 1 to 3
Stowage during transport and storage in transit	paragraphs 4 to 8

Segregation of packages containing fissile material during transport and storage in transit	paragraphs 9 and 10
Undeliverable consignments	paragraph 11
Fire fighting equipment	paragraph 12

(2) Where these Regulations are not applicable in relation to the transport of a consignment because the total activity or the activity concentration of the radioactive material in the consignment is less than the respective values specified in paragraph (1)(f) of regulation 5 (non-application of regulations), the carrier must nevertheless always ensure that the total activity in the conveyance never exceeds the value specified in paragraph (d) of regulation 28 (basic radionuclide values).

## PART VIII

### REQUIREMENTS FOR RADIOACTIVE MATERIALS AND FOR PACKAGINGS AND PACKAGES

#### Requirements for radioactive materials etc

**50.** The Table below shall have effect for the purpose of specifying in relation to the types of radioactive material and the packagings and packages described in column (1) the requirements that are applicable to that material or package or packaging in accordance with the Part of Schedule 8 indicated in column (2).

<i>(1)</i> <i>Material, packaging or package</i>	<i>(2)</i> <i>Part</i>
LSA-III material	I
Special form radioactive material	II
Low dispersible radioactive material	III
General requirements for packages and packagings	IV
Excepted packages	V
Industrial packages Type 1 (Type IP-1)	VI
Industrial packages Type 2 (Type IP-2)	VII
Industrial packages Type 3 (Type IP-3)	VIII
Packages containing uranium hexafluoride	IX
Type A packages	X
Type B(U) packages	XI
Type B(M) packages	XII
Type C packages	XIII
Packages containing fissile material	XIV

## PART IX

### TEST PROCEDURES

#### Test procedures

**51.**—(1) The Table below shall have effect for the purpose of specifying in relation to the materials and matters described in column (1) the tests that are required to be carried out in accordance with the requirements of the Part of Schedule 9 indicated in column (2).

<i>(1)</i> <i>Subject matter of test</i>	<i>(2)</i> <i>part</i>
Leaching test for LSA-III material and low dispersible radioactive material	I
Special form radioactive material	II
Low dispersible radioactive material	III
Packages	IV

(2) Demonstration of compliance with the performance standards required in any Part referred to in the Table above must be in accordance with any of the methods listed in Part V of Schedule 9.

(3) The Secretary of State may require such additional tests as he considers necessary to be made in relation to any of the materials and matters referred to in paragraph (1).

## PART X

### APPROVAL REQUIREMENTS FOR DESIGNS AND SHIPMENTS

#### General

**52.** In any case where there is no requirement under the following provisions of this Part that the competent authority must issue an approval certificate in respect of a design, the consignor must, upon the request of the Secretary of State, make available to him such documentary evidence as he requires to satisfy him that the package design does comply with the requirements in Part VIII (requirements for radioactive materials and for packagings and packages) and Part IX (test procedures).

#### Competent authority approval

**53.** The Table below shall have effect for the purpose of specifying in column (2) the type of approval that is required for designs for the items mentioned in column (1), for which approval is more fully described in the following regulations in this Part.

<i>(1)</i> <i>Item</i>	<i>(2)</i> <i>Type of approval</i>
Special form radioactive material	Unilateral
Low dispersible radioactive material	Multilateral

<i>(1)</i> <i>Item</i>	<i>(2)</i> <i>Type of approval</i>
Packages containing 0.1 kg (or more) of uranium hexafluoride complying with regulation 55(1)(a)	Multilateral
Packages containing 0.1 kg (or more) of uranium hexafluoride complying with regulation 55(1)(b)	Unilateral after 31 December 2003
All packages containing fissile material (unless excepted under paragraph 3 of Part XIV of Schedule 8)	Multilateral
Type B(U) packages	Unilateral
Type B(M) packages	Multilateral
Type C packages	Unilateral
Special arrangements	Multilateral
Certain shipments	Multilateral
Type B(U) packages for low dispersible radioactive material	Multilateral

#### **Approval of special form and low dispersible radioactive material**

54.—(1) The design—

- (a) for any special form radioactive material, must have unilateral approval; and
- (b) for any low dispersible radioactive material, must have multilateral approval.

(2) Where the design for special form radioactive material or for low dispersible radioactive material originates in Great Britain, the application for the approval of the design must include the matters set out in Part I of Schedule 10.

(3) An approval certificate that a material meets the requirements for special form or low dispersible radioactive material shall be in the form issued by the Secretary of State certifying that the design meets the requirements of IAEA 1996.

(4) This regulation is subject to the applicable savings and transitional provisions in Part II (savings etc).

#### **Approval of packages designed to contain uranium hexafluoride**

55.—(1) The following requirements apply in respect of the approval of package designs to contain 0.1 kg or more of uranium hexafluoride—

- (a) each design that meets the requirements of paragraph 4 of Part IX of Schedule 8, must have multilateral approval;
- (b) after 31 December 2003, each design that meets the requirements of paragraphs 1 to 3 of Part IX of Schedule 8, must have unilateral approval; and
- (c) the application for approval must include all information necessary to satisfy the Secretary of State that the design meets the appropriate requirements and a specification of the applicable quality assurance programme as required by regulation 18 (quality and compliance assurance programmes; prohibitions etc).

(2) An approval certificate that the design meets the requirements for a package containing uranium hexafluoride shall be in the form issued by the Secretary of State certifying that the design meets the requirements of IAEA 1996.

#### **Approval of Type B(U) and Type C package designs**

**56.**—(1) Each Type B(U) and Type C package design must have unilateral approval.

(2) But a Type B(U) package design for low dispersible radioactive material, and a package design for fissile material (to which regulation 58 (approval of package designs to contain fissile material) applies) must each have multilateral approval.

(3) An application for the approval of the Secretary of State must include the matters listed in Part II of Schedule 10.

(4) An approval certificate that a package design meets the requirements for a Type B(U) or a Type C package shall be in the form issued by the Secretary of State Certifying that the design meets the requirements of IAEA 1996.

(5) This regulation is subject to the applicable savings and transitional provisions in Part II (savings etc).

#### **Approval of Type B(M) package designs**

**57.**—(1) Each Type B(M) package design (including those for fissile material to which regulation 58 (approval of package designs to contain fissile material) applies and for low dispersible radioactive material) must have multilateral approval.

(2) An application for multilateral approval of a Type B(M) package must include—

(a) the matters required to be listed under paragraph 3 of regulation 56 (approval of Type B(U) and Type C package designs) in respect of Type B(U) packages, and

(b) the matters listed in Part III of Schedule 10.

(3) An approval certificate that a design meets the requirements for a Type B(M) package shall be in the form issued by the Secretary of State certifying that the design meets the requirements of IAEA 1996.

(4) This regulation is subject to the applicable savings and transitional provisions in Part II (savings etc).

#### **Approval of packages designed to contain fissile material**

**58.**—(1) Each package designed to contain fissile material must (unless excepted in accordance with paragraph 3 of Part XIV of Schedule 8 from the requirements that apply specifically to packages containing fissile material) have multilateral approval.

(2) An application for approval under paragraph (1) must include the matters listed in Part IV of Schedule 10.

(3) An approval certificate that a design meets the requirements for a package designed to contain fissile material shall be in the form issued by the Secretary of State certifying that the design meets the requirements of IAEA 1996.

(4) This regulation is subject to the applicable savings and transitional provisions in Part II (savings etc).

**Notification and registration of serial numbers**

**59.**—(1) The manufacturer of any packaging manufactured after the date of the coming into force of these Regulations to a design approved by the Secretary of State under regulation 12 (package approval under IAEA 1985), regulation 56 (approval of Type B(U) and Type C package designs), regulation 57 (approval of Type B(M) package designs) and regulation 58 (approval of package designs to contain fissile material) must promptly notify the Secretary of State in writing of the serial number assigned to that packaging.

(2) The owner of any other packaging manufactured to a design approved by the Secretary of State under these Regulations must promptly notify the Secretary of State in writing of the serial number assigned to that packaging.

**Approval of shipments**

**60.**—(1) Multilateral approval is required for the following—

- (a) the shipment of Type B(M) packages which—
  - (i) do not conform with the requirements set out in paragraph 5 of Part X of Schedule 8, or
  - (ii) are designed to allow controlled intermittent venting;
- (b) the shipment of Type B(M) packages that contain radioactive material with an activity greater than whichever is the lower of either 3000A<sub>1</sub> or 3000A<sub>2</sub> (as appropriate) or 1000TBq; and
- (c) the shipment of packages that contain fissile material if the sum of the criticality safety indexes of the packages exceeds 50.

(2) An application to the Secretary of State for shipment approval must include the matters listed in Part V of Schedule 10 and, upon approval of the shipment, the Secretary of State will issue an approval certificate.

**Approval of shipments under special arrangement**

**61.**—(1) Each consignment that is transported under special arrangement must have multilateral approval.

(2) An application to the Secretary of State for approval of shipments under special arrangement must include the matters listed in Part VI of Schedule 10.

(3) Where the secretary of State is satisfied as to the approval of a shipment under special arrangement, he shall issue an approval certificate.

(4) The approval of the competent authority of another state shall be evidenced by a certificate issued by that competent authority.

**PART XI****APPROVAL CERTIFICATES****Types of approval certificates**

**62.**—(1) The Secretary of State may issue the following type of certificate under these Regulations—

- (a) a special form radioactive material approval certificate;
- (b) a low dispersible radioactive material approval certificate;



- (c) a special arrangement approval certificate;
  - (d) a shipment approval certificate;
  - (e) a package design approval certificate; and
  - (f) a basic radionuclide values certificate.
- (2) The certificates mentioned in (d) and (e) above may be combined into a single certificate.

### **Identification marks**

**63.** Each of the certificates mentioned in regulation 62 (types of approval certificates) shall have an identification mark which shall be assigned by the Secretary of State

### **Content of approval certificates**

**64.** The information to be contained in each approval certificate issued by the Secretary of State must include—

- (a) for special form radioactive material, that set out in Part I of Schedule 12;
- (b) for low dispersible radioactive material, that set out in Part I of Schedule 12;
- (c) for a special arrangement, that set out in Part II of Schedule 12;
- (d) for a shipment, that set out in Part III of Schedule 12;
- (e) for the design of a package, that set out in Part IV of Schedule 12; and
- (f) for a combined package design and a shipment, that set out in Part V of Schedule 12.

### **Validation of approval certificates**

**65.**—(1) Where shipment is to be made through or into Great Britain, multilateral approval may be demonstrated by means of the validation by the Secretary of State of the original certificate (being one or other of the types of certificate mentioned in regulation 64 (content of approval certificates)).

(2) Validation may be by means of an endorsement on the original certificate or the issue of a new endorsement, annex or supplement.

## **PART XII**

### **RADIOLOGICAL EMERGENCIES AND INTERVENTION ARRANGEMENTS**

#### **Interpretation of expressions used in this Part**

**66.** In this Part—

“assist in the intervention” means the taking of such steps, as it is reasonable and practicable in the prevailing circumstances to take, in order to prevent or decrease exposure; the circumstances include, in particular—

- (a) the weather conditions;
- (b) the time of the occurrence of the emergency;
- (c) the distribution of the local population;
- (d) the nature and content of the package involved;
- (e) the stability of the radioactive material involved;
- (f) the nature of the local geography and ecology;

- (g) any other prevailing hazards; and
- (h) the relative importance of the emergency in relation to other calls that are being made upon the emergency services;

“emergency arrangements” means the documented plan drawn up by the consignor pursuant to regulation 68 (duties of consignor and carrier with regard to the preparation of emergency arrangements) for the purpose of providing for intervention in cases where a radiological emergency occurs during the course of transport of a consignment and which sets out the steps to be taken by those concerned with that transport to make an immediate provisional assessment of the circumstances and consequences of the emergency and to assist with intervention; and which contains provision, where the situation so requires, for intervention relating to—

- (a) the source (so as to reduce or stop the direct radiation and emission of radionuclides);
- (b) the environment (so as to reduce the transfer of radioactive material to individuals); and
- (c) individuals (so as to reduce their exposure or to organise the treatment of victims);

“exposure” means the process of being exposed to ionising radiation;

“initiate the emergency arrangements” means the taking of such steps, as it is reasonable and practicable to take, in order to put into effect the actions that have been planned for in the emergency arrangements;

“intervention” means any human activity taken to prevent or decrease the exposure of individuals to ionising radiation from a consignment involved in a radiological emergency by acting either upon that consignment or upon the transmission pathway giving rise to that exposure or upon the individuals so exposed;

“notifiable event” means any event where—

- (a) radioactive material is lost, escapes or is unlawfully removed from the vehicle carrying the material;
- (b) any package carried in or on a vehicle is opened or otherwise damaged (whether or not the package is still in or on the vehicle);
- (c) the vehicle carrying the radioactive material overturns (including being turned on its side) or suffers serious damage or is involved in a fire; or
- (d) a radiological emergency occurs; and

“radiological emergency” means a situation arising during the course of the transport of a consignment that requires urgent action in order to protect workers, members of the public or the population (either partially or as a whole) from exposure.

### **Duties with respect to the monitoring of particular persons**

67.—(1) For the purposes of this regulation, the provisions of Part V of the Ionising Radiations Regulations 1999<sup>(16)</sup> (“the 1999 Regulations”) shall be applicable so that any person (including an employee of a carrier, consignor or consignee) who assists in an intervention and is liable to be subjected to emergency exposure shall be treated as being a person classified pursuant to regulation 20 of the 1999 Regulations and, accordingly, the carrier, consignor or consignee shall have the same duties with regard to the monitoring of such person as are imposed upon an “employer” in regulations 21 to 26 of the 1999 Regulations.

(2) In the exceptional circumstances of saving human lives, there may be an emergency exposure whereby the dose limit specified in paragraph 1, 2, 6, 7 and 8 (Workers over 18 and other persons) of

<sup>(16)</sup> S.I. 1999/3232.

Schedule 4 (dose limits) of the 1999 Regulations could be exceeded to such persons, but only where those persons are volunteers and have been informed of the risks involved in their intervention.

(3) “Employee” has the same meaning as in paragraph (1) of regulation 24 (radiation protection programme).

(4) “Emergency exposure” means an exposure of persons implementing the necessary rapid action to bring help to endangered persons or to prevent a large number of persons from being exposed to ionising radiation or to save valuable goods or a valuable installation, whereby the dose limit specified in paragraphs 1 and 2 of Schedule 4 (dose limits) of the 1999 Regulations could be exceeded.

### **Duties of consignor and carrier with regard to the preparation of emergency arrangements**

**68.**—(1) Before the transport of a package begins, the consignor thereof must have drawn up a documented plan with regard to emergency arrangements for that package.

(2) The emergency arrangements made pursuant to paragraph (1) shall be prepared having regard to the following principles

- (a) intervention is to be undertaken only if the damage due to the radiation resulting from the radiation emergency is sufficient to justify the potential harm and the potential cost (including the social cost) of that intervention;
- (b) the form, scale and duration of the intervention is to be optimised so that the benefit to health will be greater than any harm that might be associated with the intervention itself;
- (c) the dose limits provided for in Schedule 4 of the Ionising Radiations Regulations 1999 and
- (d) the Emergency Reference Levels specified by the National Radiological Protection Board (NRPB) pursuant to a direction under section 1(7) of the Radiological Protection Act 1970(17).

(3) In preparing the emergency arrangements under paragraph (1), the consignor may use or employ the services of any person (including a person who is a carrier) who has expertise in matters relating to the transport of radioactive material or of contamination.

(4) The consignor must review and, whenever necessary, revise his emergency arrangements and shall ensure that at suitable intervals they are tested.

(5) A carrier must not undertake the transport of, or cause the transport to be made of, any consignment unless he has in his possession a copy of the statement required to be given by the consignor pursuant to paragraph 23(c) of Schedule 6 of these Regulations (emergency arrangements appropriate to the consignment).

### **Duties of drivers, carriers and consignors in the event of the occurrence of a radiological emergency**

**69.**—(1) This regulation sets out the duties respectively of the driver, the carrier and the consignor in the event of the occurrence of a radiological emergency.

(2) The driver of the vehicle transporting radioactive material who discovers or has reason to believe that a notifiable event has occurred in relation to the vehicle he is driving must—

- (a) immediately notify the police and (where appropriate) the fire brigade and the consignor of that event;
- (b) initiate the emergency arrangements in respect of any radiological emergency and
- (c) assist in the intervention that is made in connection with that radiological emergency.

- (3) A carrier of radioactive material who becomes aware of the occurrence of a notifiable event in relation to the material he is carrying must—
- (a) immediately notify the police (unless the driver of the vehicle has already done so) and the Secretary of State of that event;
  - (b) assist in the intervention that is made in connection with any radiological emergency; and
  - (c) as soon as is reasonable practicable, arrange for the examination of the load that is carried in or on the vehicle so as to determine whether contamination has arisen and, if it has, to arrange for the safe disposal of any part of the load that has been contaminated and for the decontamination of the vehicle.
- (4) A consignor of radioactive material who becomes aware of the occurrence of a notifiable event in relation to his consignment must—
- (a) immediately notify the police and the Secretary of State of that event (unless either the driver or the carrier has already done so);
  - (b) assist in the intervention that is made in connection with any radiological emergency; and
  - (c) provide the Secretary of State with details of the incident that gave rise to that emergency.
- (5) Whenever a consignor becomes aware that emergency arrangements have been initiated in relation to his consignment he must notify the Secretary of State of the initiation of those arrangements even if, in the event, no intervention was made pursuant to those arrangements.

#### **Packages involved in a radiological emergency**

**70.** A package that has been involved in a radiological emergency shall not be transported or caused to be transported unless the consignor or his agent has examined it and the consignor is satisfied that it complies with the requirements of these Regulations and he issues a certificate to that effect.

#### **Powers of inspectors and the Secretary of State in relation to emergency arrangements**

**71.—(1)** When requested by an inspector, the carrier and the consignor must provide that inspector, within such reasonable time as the inspector may specify, with a copy of such documents relating to the emergency arrangements as may have been requested.

(2) The Secretary of State may review the emergency arrangements and may at any time by notice in writing to a carrier or consignee require—

- (a) that those arrangements be tested and, if thought appropriate by the Secretary of State, that a rehearsal be carried out of them; and
- (b) that a general or specific revision or improvement be made of those arrangements.

(3) A carrier or consignor upon whom a request is made under paragraph (1) or upon whom notice is served under paragraph (2) must comply with that request or with the requirements of that notice.

## **PART XIII**

### **MISCELLANEOUS**

#### **Retention and production of information**

**72.—(1)** The consignor of any consignment must retain for 2 years from the date on which the transport of that consignment begins any information in his possession derived from measurements of contamination of that consignment.

(2) The user of any package, packaging or special form radioactive material or low dispersible radioactive material shall retain any information in his possession relating to the design, manufacture, testing, use and maintenance of that package, packaging or material, including (without prejudice to the generality of the foregoing) specifications, calculations, test results, quality assurance programmes and manufacturing records, for so long as the package, packaging or material is in use for the transport of radioactive material and for a period of at least two years after the final use of the package, packaging or material.

(3) An inspector may require the user of any package, packaging or special form radioactive material or low dispersible radioactive material to produce such information in his possession relating to that package, packaging or material as the inspector may specify.

(4) In paragraphs (2) and (3) “user” has the same meaning as in paragraph (5) of regulation 18 (quality and compliance assurance programmes, prohibitions etc.)

### **Production of documents**

73. An examiner, an inspector or a constable in uniform may require the carrier of any radioactive material or the driver of any vehicle transporting radioactive material to produce for inspection such documents relating to that material and required by these Regulations as the examiner, inspector or constable may specify

### **Evaluation of radiation emissions**

74. For the purpose of ensuring that the transport of radioactive material does not cause any injury to health, or any damage to property or to the environment, the Secretary of State shall arrange for periodic assessments to be carried out to evaluate the radiation emissions arising from such transport.

### **Transport documents for regular consignments**

75.—(1) Where the same packaging with the same radioactive contents is consigned as a package on a regular basis by the same consignor, who is also the carrier of that package, the consignor may issue a regular consignment certificate for that package in accordance with the provisions of Schedule 13.

(2) The consignor of any package in respect of which he holds a current regular consignment certificate issued under paragraph (1) must carry in the vehicle in which the consignment is transported a document containing a statement that the consignment is covered by a regular consignment certificate issued under this regulation, the date and contents of that certificate, a record (including destinations and dates) of all consignments made under that certificate, and an expiry date for the document not later than three months after the date of the declaration contained in that certificate.

(3) The consignor of any package falling within paragraph (2) must retain a copy of the document described in paragraph (2), or a complete record of the contents of that document, for two years from the date on which the transport of that package begins.

Signed by the authority of the Secretary of State

April 2002

Parliamentary Under Secretary of State  
Department for Transport, Local Government  
and the Regions

## SCHEDULE 1

Regulations 5, 25, 29, 41 and 43

## TABLES

## TABLE I

## Basic Radionuclide Values

(1) Radionuclide (atomic number)	(2) $A_1$  (TBq)	(3) $A_2$  (TBq)	(4) Activity concentration for exempt material (Bq/g)	(5) Activity limit for an exempt consignment (Bq)
Actinium (89)				
Ac-225 <sup>(a)</sup>	$8 \times 10^{-1}$	$6 \times 10^{-3}$	$1 \times 10^1$	$1 \times 10^4$
Ac-227 <sup>(a)</sup>	$9 \times 10^{-1}$	$9 \times 10^{-5}$	$1 \times 10^{-1}$	$1 \times 10^3$
Ac-228	$6 \times 10^{-1}$	$5 \times 10^{-1}$	$1 \times 10^1$	$1 \times 10^6$
Silver (47)				
Ag-105	$2 \times 10^0$	$2 \times 10^0$	$1 \times 10^2$	$1 \times 10^6$
Ag-108 <sup>(a)</sup>	$7 \times 10^{-1}$	$7 \times 10^{-1}$	$1 \times 10^{1(b)}$	$1 \times 10^{6(b)}$
Ag-110m <sup>(a)</sup>	$4 \times 10^{-1}$	$4 \times 10^{-1}$	$1 \times 10^1$	$1 \times 10^6$
Ag-111	$2 \times 10^0$	$6 \times 10^{-1}$	$1 \times 10^3$	$1 \times 10^6$
Aluminium (13)				
Al-26	$1 \times 10^{-1}$	$1 \times 10^{-1}$	$1 \times 10^1$	$1 \times 10^5$
Americium (95)				
Am-241	$1 \times 10^1$	$1 \times 10^{-3}$	$1 \times 10^0$	$1 \times 10^4$
Am-242m <sup>(a)</sup>	$1 \times 10^1$	$1 \times 10^{-3}$	$1 \times 10^{0(b)}$	$1 \times 10^{4(b)}$
Am-243 <sup>(a)</sup>	$5 \times 10^0$	$1 \times 10^{-3}$	$1 \times 10^{0(b)}$	$1 \times 10^{3(b)}$
Argon (18)				
Ar-37	$4 \times 10^1$	$4 \times 10^1$	$1 \times 10^6$	$1 \times 10^8$
Ar-39	$4 \times 10^1$	$2 \times 10^1$	$1 \times 10^7$	$1 \times 10^4$
Ar-41	$3 \times 10^{-1}$	$3 \times 10^{-1}$	$1 \times 10^2$	$1 \times 10^9$
Arsenic (33)				
As-72	$3 \times 10^{-1}$	$3 \times 10^{-1}$	$1 \times 10^1$	$1 \times 10^5$
As-73	$4 \times 10^1$	$4 \times 10^1$	$1 \times 10^3$	$1 \times 10^7$
As-74	$1 \times 10^0$	$9 \times 10^{-1}$	$1 \times 10^1$	$1 \times 10^6$

*Status: This is the original version (as it was originally made).*

(1) Radionuclide (atomic number)	(2) $A_1$  (TBq)	(3) $A_2$  (TBq)	(4) Activity concentration for exempt material (Bq/g)	(5) Activity limit for an exempt consignment (Bq)
As-76	$3 \times 10^{-1}$	$3 \times 10^{-1}$	$1 \times 10^2$	$1 \times 10^5$
As-77	$2 \times 10^1$	$7 \times 10^{-1}$	$1 \times 10^3$	$1 \times 10^6$
Astatine (85)				
At-211 <sup>(a)</sup>	$2 \times 10^1$	$5 \times 10^{-1}$	$1 \times 10^3$	$1 \times 10^7$
Gold (79)				
Au-193	$7 \times 10^0$	$2 \times 10^0$	$1 \times 10^2$	$1 \times 10^7$
Au-194	$1 \times 10^0$	$1 \times 10^0$	$1 \times 10^1$	$1 \times 10^6$
Au-195	$1 \times 10^1$	$6 \times 10^0$	$1 \times 10^2$	$1 \times 10^7$
Au-198	$1 \times 10^0$	$6 \times 10^{-1}$	$1 \times 10^2$	$1 \times 10^6$
Au-199	$1 \times 10^1$	$6 \times 10^{-1}$	$1 \times 10^2$	$1 \times 10^6$
Barium (56)				
Ba-131 <sup>(a)</sup>	$2 \times 10^0$	$2 \times 10^0$	$1 \times 10^2$	$1 \times 10^6$
Ba-133	$3 \times 10^0$	$3 \times 10^0$	$1 \times 10^2$	$1 \times 10^6$
Ba-133m	$2 \times 10^1$	$6 \times 10^{-1}$	$1 \times 10^2$	$1 \times 10^6$
Ba-140 <sup>(a)</sup>	$5 \times 10^{-1}$	$3 \times 10^{-1}$	$1 \times 10^{1(b)}$	$1 \times 10^{5(b)}$
Beryllium (4)				
Be-7	$2 \times 10^1$	$2 \times 10^1$	$1 \times 10^3$	$1 \times 10^7$
Be-10	$4 \times 10^1$	$6 \times 10^{-1}$	$1 \times 10^4$	$1 \times 10^6$
Bismuth (83)				
Bi-205	$7 \times 10^{-1}$	$7 \times 10^{-1}$	$1 \times 10^1$	$1 \times 10^6$
Bi-206	$3 \times 10^{-1}$	$3 \times 10^{-1}$	$1 \times 10^1$	$1 \times 10^5$
Bi-207	$7 \times 10^{-1}$	$7 \times 10^{-1}$	$1 \times 10^1$	$1 \times 10^6$
Bi-210	$1 \times 10^0$	$6 \times 10^{-1}$	$1 \times 10^3$	$1 \times 10^6$
Bi-210m <sup>(a)</sup>	$6 \times 10^{-1}$	$2 \times 10^{-2}$	$1 \times 10^1$	$1 \times 10^5$
Bi-212 <sup>(a)</sup>	$7 \times 10^{-1}$	$6 \times 10^{-1}$	$1 \times 10^{1(b)}$	$1 \times 10^{5(b)}$
Berkelium (97)				
Bk-247	$8 \times 10^0$	$8 \times 10^{-4}$	$1 \times 10^0$	$1 \times 10^4$
Bk-249 <sup>(a)</sup>	$4 \times 10^1$	$3 \times 10^{-1}$	$1 \times 10^3$	$1 \times 10^6$



(1) Radionuclide (atomic number)	(2) $A_1$  (TBq)	(3) $A_2$  (TBq)	(4) Activity concentration for exempt material (Bq/g)	(5) Activity limit for an exempt consignment (Bq)
Bromine (35)				
Br-76	$4 \times 10^{-1}$	$4 \times 10^{-1}$	$1 \times 10^1$	$1 \times 10^5$
Br-77	$3 \times 10^0$	$3 \times 10^0$	$1 \times 10^2$	$1 \times 10^6$
Br-82	$4 \times 10^{-1}$	$4 \times 10^{-1}$	$1 \times 10^1$	$1 \times 10^6$
Carbon (6)				
C-11	$1 \times 10^0$	$6 \times 10^{-1}$	$1 \times 10^1$	$1 \times 10^6$
C-14	$4 \times 10^1$	$3 \times 10^0$	$1 \times 10^4$	$1 \times 10^7$
Calcium (20)				
Ca-41	Unlimited	Unlimited	$1 \times 10^5$	$1 \times 10^7$
Ca-45	$4 \times 10^1$	$1 \times 10^0$	$1 \times 10^4$	$1 \times 10^7$
Ca-47 <sup>(a)</sup>	$3 \times 10^0$	$3 \times 10^{-1}$	$1 \times 10^1$	$1 \times 10^6$
Cadmium (48)				
Cd-109;	$3 \times 10^1$	$2 \times 10^0$	$1 \times 10^4$	$1 \times 10^6$
Cd-113m	$4 \times 10^1$	$5 \times 10^{-1}$	$1 \times 10^3$	$1 \times 10^6$
Cd-115 <sup>(a)</sup>	$3 \times 10^0$	$4 \times 10^{-1}$	$1 \times 10^2$	$1 \times 10^6$
Cd-115m	$5 \times 10^{-1}$	$5 \times 10^{-1}$	$1 \times 10^3$	$1 \times 10^6$
Cerium (58)				
Ce-139	$7 \times 10^0$	$2 \times 10^0$	$1 \times 10^2$	$1 \times 10^6$
Ce-141	$2 \times 10^1$	$6 \times 10^{-1}$	$1 \times 10^2$	$1 \times 10^7$
Ce-143	$9 \times 10^{-1}$	$6 \times 10^{-1}$	$1 \times 10^2$	$1 \times 10^6$
Ce-144 <sup>(a)</sup>	$2 \times 10^{-1}$	$2 \times 10^{-1}$	$1 \times 10^{2(b)}$	$1 \times 10^{5(b)}$
Californium (98)				
Cf-248	$4 \times 10^1$	$6 \times 10^{-3}$	$1 \times 10^1$	$1 \times 10^4$
Cf-249	$3 \times 10^0$	$8 \times 10^{-4}$	$1 \times 10^0$	$1 \times 10^3$
Cf-250	$2 \times 10^1$	$2 \times 10^{-3}$	$1 \times 10^1$	$1 \times 10^4$
Cf-251	$7 \times 10^0$	$7 \times 10^{-4}$	$1 \times 10^0$	$1 \times 10^3$
Cf-252	$5 \times 10^{-2}$	$3 \times 10^{-3}$	$1 \times 10^1$	$1 \times 10^4$
Cf-253 <sup>(a)</sup>	$4 \times 10^1$	$4 \times 10^{-2}$	$1 \times 10^2$	$1 \times 10^5$

*Status: This is the original version (as it was originally made).*

<i>(1)</i> <i>Radionuclide</i> <i>(atomic number)</i>	<i>(2)</i> <i>A<sub>1</sub></i>  <i>(TBq)</i>	<i>(3)</i> <i>A<sub>2</sub></i>  <i>(TBq)</i>	<i>(4)</i> <i>Activity</i> <i>concentration</i> <i>for exempt</i> <i>material</i> <i>(Bq/g)</i>	<i>(5)</i> <i>Activity limit</i> <i>for an exempt</i> <i>consignment</i> <i>(Bq)</i>
Cf-254	$1 \times 10^{-3}$	$1 \times 10^{-3}$	$1 \times 10^0$	$1 \times 10^3$
Chlorine (17)				
Cl-36	$1 \times 10^1$	$6 \times 10^{-1}$	$1 \times 10^4$	$1 \times 10^6$
Cl-38	$2 \times 10^{-1}$	$2 \times 10^{-1}$	$1 \times 10^1$	$1 \times 10^5$
Curium (96)				
Cm-240	$4 \times 10^1$	$2 \times 10^{-2}$	$1 \times 10^2$	$1 \times 10^5$
Cm-241	$2 \times 10^0$	$1 \times 10^0$	$1 \times 10^2$	$1 \times 10^6$
Cm-242	$4 \times 10^1$	$1 \times 10^{-2}$	$1 \times 10^2$	$1 \times 10^5$
Cm-243	$9 \times 10^0$	$1 \times 10^{-3}$	$1 \times 10^0$	$1 \times 10^4$
Cm-244	$2 \times 10^1$	$2 \times 10^{-3}$	$1 \times 10^1$	$1 \times 10^4$
Cm-245	$9 \times 10^0$	$9 \times 10^{-4}$	$1 \times 10^0$	$1 \times 10^3$
Cm-246	$9 \times 10^0$	$9 \times 10^{-4}$	$1 \times 10^0$	$1 \times 10^3$
Cm-247 <sup>(a)</sup>	$3 \times 10^0$	$1 \times 10^{-3}$	$1 \times 10^0$	$1 \times 10^4$
Cm-248	$2 \times 10^{-2}$	$3 \times 10^{-4}$	$1 \times 10^0$	$1 \times 10^3$
Cobalt (27)				
Co-55	$5 \times 10^{-1}$	$5 \times 10^{-1}$	$1 \times 10^1$	$1 \times 10^6$
Co-56	$3 \times 10^{-1}$	$3 \times 10^{-1}$	$1 \times 10^1$	$1 \times 10^5$
Co-57	$1 \times 10^1$	$1 \times 10^1$	$1 \times 10^2$	$1 \times 10^6$
Co-58	$1 \times 10^0$	$1 \times 10^0$	$1 \times 10^1$	$1 \times 10^6$
Co-58m	$4 \times 10^1$	$4 \times 10^1$	$1 \times 10^4$	$1 \times 10^7$
Co-60	$4 \times 10^{-1}$	$4 \times 10^{-1}$	$1 \times 10^1$	$1 \times 10^5$
Chromium (24)				
Cr-51	$3 \times 10^1$	$3 \times 10^1$	$1 \times 10^3$	$1 \times 10^7$
Caesium (55)				
Cs-129	$4 \times 10^0$	$4 \times 10^0$	$1 \times 10^2$	$1 \times 10^5$
Cs-131	$3 \times 10^1$	$3 \times 10^1$	$1 \times 10^3$	$1 \times 10^6$
Cs-132	$1 \times 10^0$	$1 \times 10^0$	$1 \times 10^1$	$1 \times 10^5$
Cs-134	$7 \times 10^{-1}$	$7 \times 10^{-1}$	$1 \times 10^1$	$1 \times 10^4$

(1) Radionuclide (atomic number)	(2) $A_1$  (TBq)	(3) $A_2$  (TBq)	(4) Activity concentration for exempt material (Bq/g)	(5) Activity limit for an exempt consignment (Bq)
Cs-134m	$4 \times 10^1$	$6 \times 10^{-1}$	$1 \times 10^3$	$1 \times 10^5$
Cs-135	$4 \times 10^1$	$1 \times 10^0$	$1 \times 10^4$	$1 \times 10^7$
Cs-136	$5 \times 10^{-1}$	$5 \times 10^{-1}$	$1 \times 10^1$	$1 \times 10^5$
Cs-137 <sup>(a)</sup>	$2 \times 10^0$	$6 \times 10^{-1}$	$1 \times 10^{1(b)}$	$1 \times 10^{4(b)}$
Copper (29)				
Cu-64	$6 \times 10^0$	$1 \times 10^0$	$1 \times 10^2$	$1 \times 10^6$
Cu-67	$1 \times 10^1$	$7 \times 10^{-1}$	$1 \times 10^2$	$1 \times 10^6$
Dysprosium (66)				
Dy-159	$2 \times 10^1$	$2 \times 10^1$	$1 \times 10^3$	$1 \times 10^7$
Dy-165	$9 \times 10^{-1}$	$6 \times 10^{-1}$	$1 \times 10^3$	$1 \times 10^6$
Dy-166 <sup>(a)</sup>	$9 \times 10^{-1}$	$3 \times 10^{-1}$	$1 \times 10^3$	$1 \times 10^6$
Erbium (68)				
Er-169	$4 \times 10^1$	$1 \times 10^0$	$1 \times 10^4$	$1 \times 10^7$
Er-171	$8 \times 10^{-1}$	$5 \times 10^{-1}$	$1 \times 10^2$	$1 \times 10^6$
Europium (63)				
Eu-147	$2 \times 10^0$	$2 \times 10^0$	$1 \times 10^2$	$1 \times 10^6$
Eu-148	$5 \times 10^{-1}$	$5 \times 10^{-1}$	$1 \times 10^1$	$1 \times 10^6$
Eu-149	$2 \times 10^1$	$2 \times 10^1$	$1 \times 10^2$	$1 \times 10^7$
Eu-150(short lived)	$2 \times 10^0$	$7 \times 10^{-1}$	$1 \times 10^3$	$1 \times 10^6$
Eu-150(long lived)	$7 \times 10^{-1}$	$7 \times 10^{-1}$	$1 \times 10^1$	$1 \times 10^6$
Eu-152	$1 \times 10^0$	$1 \times 10^0$	$1 \times 10^1$	$1 \times 10^6$
Eu-152m	$8 \times 10^{-1}$	$8 \times 10^{-1}$	$1 \times 10^2$	$1 \times 10^6$
Eu-154	$9 \times 10^{-1}$	$6 \times 10^{-1}$	$1 \times 10^1$	$1 \times 10^6$
Eu-155	$2 \times 10^1$	$3 \times 10^0$	$1 \times 10^2$	$1 \times 10^7$
Eu-156	$7 \times 10^{-1}$	$7 \times 10^{-1}$	$1 \times 10^1$	$1 \times 10^6$
Fluorine (9)				
F-18	$1 \times 10^0$	$6 \times 10^{-1}$	$1 \times 10^1$	$1 \times 10^6$

*Status: This is the original version (as it was originally made).*

(1) Radionuclide (atomic number)	(2) $A_1$  (TBq)	(3) $A_2$  (TBq)	(4) Activity concentration for exempt material (Bq/g)	(5) Activity limit for an exempt consignment (Bq)
Iron (26)				
Fe-52 <sup>(a)</sup>	$3 \times 10^{-1}$	$3 \times 10^{-1}$	$1 \times 10^1$	$1 \times 10^6$
Fe-55	$4 \times 10^1$	$4 \times 10^1$	$1 \times 10^4$	$1 \times 10^6$
Fe-59	$9 \times 10^{-1}$	$9 \times 10^{-1}$	$1 \times 10^1$	$1 \times 10^6$
Fe-60 <sup>(a)</sup>	$4 \times 10^1$	$2 \times 10^{-1}$	$1 \times 10^2$	$1 \times 10^5$
Gallium (31)				
Ga-67	$7 \times 10^0$	$3 \times 10^0$	$1 \times 10^2$	$1 \times 10^6$
Ga-68	$5 \times 10^{-1}$	$5 \times 10^{-1}$	$1 \times 10^1$	$1 \times 10^5$
Ga-72	$4 \times 10^{-1}$	$4 \times 10^{-1}$	$1 \times 10^1$	$1 \times 10^5$
Gadolinium (64)				
Gd-146 <sup>(a)</sup>	$5 \times 10^{-1}$	$5 \times 10^{-1}$	$1 \times 10^1$	$1 \times 10^6$
Gd-148	$2 \times 10^1$	$2 \times 10^{-3}$	$1 \times 10^1$	$1 \times 10^4$
Gd-153	$1 \times 10^1$	$9 \times 10^0$	$1 \times 10^2$	$1 \times 10^7$
Gd-159	$3 \times 10^0$	$6 \times 10^{-1}$	$1 \times 10^3$	$1 \times 10^6$
Germanium (32)				
Ge-68 <sup>(a)</sup>	$5 \times 10^{-1}$	$5 \times 10^{-1}$	$1 \times 10^1$	$1 \times 10^5$
Ge-71	$4 \times 10^1$	$4 \times 10^1$	$1 \times 10^4$	$1 \times 10^8$
Ge-77	$3 \times 10^{-1}$	$3 \times 10^{-1}$	$1 \times 10^1$	$1 \times 10^5$
Hafnium (72)				
Hf-172 <sup>(a)</sup>	$6 \times 10^{-1}$	$6 \times 10^{-1}$	$1 \times 10^1$	$1 \times 10^6$
Hf-175	$3 \times 10^0$	$3 \times 10^0$	$1 \times 10^2$	$1 \times 10^6$
Hf-181	$2 \times 10^0$	$5 \times 10^{-1}$	$1 \times 10^1$	$1 \times 10^6$
Hf-182	Unlimited	Unlimited	$1 \times 10^2$	$1 \times 10^6$
Mercury (80)				
Hg-194 <sup>(a)</sup>	$1 \times 10^0$	$1 \times 10^0$	$1 \times 10^1$	$1 \times 10^6$
Hg-195m <sup>(a)</sup>	$3 \times 10^0$	$7 \times 10^{-1}$	$1 \times 10^2$	$1 \times 10^6$
Hg-197	$2 \times 10^1$	$1 \times 10^1$	$1 \times 10^2$	$1 \times 10^7$
Hg-197m	$1 \times 10^1$	$4 \times 10^{-1}$	$1 \times 10^2$	$1 \times 10^6$

(1) Radionuclide (atomic number)	(2) $A_1$  (TBq)	(3) $A_2$  (TBq)	(4) Activity concentration for exempt material (Bq/g)	(5) Activity limit for an exempt consignment (Bq)
Hg-203	$5 \times 10^0$	$1 \times 10^0$	$1 \times 10^2$	$1 \times 10^5$
Holmium (67)				
Ho-166	$4 \times 10^{-1}$	$4 \times 10^{-1}$	$1 \times 10^3$	$1 \times 10^5$
Ho-166m	$6 \times 10^{-1}$	$5 \times 10^{-1}$	$1 \times 10^1$	$1 \times 10^6$
Iodine (53)				
I-123	$6 \times 10^0$	$3 \times 10^0$	$1 \times 10^2$	$1 \times 10^7$
I-124	$1 \times 10^0$	$1 \times 10^0$	$1 \times 10^1$	$1 \times 10^6$
I-125	$2 \times 10^1$	$3 \times 10^0$	$1 \times 10^3$	$1 \times 10^6$
I-126	$2 \times 10^0$	$1 \times 10^0$	$1 \times 10^2$	$1 \times 10^6$
I-129	Unlimited	Unlimited	$1 \times 10^2$	$1 \times 10^5$
I-131	$3 \times 10^0$	$7 \times 10^{-1}$	$1 \times 10^2$	$1 \times 10^6$
I-132	$4 \times 10^{-1}$	$4 \times 10^{-1}$	$1 \times 10^1$	$1 \times 10^5$
I-133	$7 \times 10^{-1}$	$6 \times 10^{-1}$	$1 \times 10^1$	$1 \times 10^6$
I-134	$3 \times 10^{-1}$	$3 \times 10^{-1}$	$1 \times 10^1$	$1 \times 10^5$
I-135 <sup>(a)</sup>	$6 \times 10^{-1}$	$6 \times 10^{-1}$	$1 \times 10^1$	$1 \times 10^6$
Indium (49)				
In-111	$3 \times 10^0$	$3 \times 10^0$	$1 \times 10^2$	$1 \times 10^6$
In-113m	$4 \times 10^0$	$2 \times 10^0$	$1 \times 10^2$	$1 \times 10^6$
In-114m <sup>(a)</sup>	$1 \times 10^1$	$5 \times 10^{-1}$	$1 \times 10^2$	$1 \times 10^6$
In-115m	$7 \times 10^0$	$1 \times 10^0$	$1 \times 10^2$	$1 \times 10^6$
Iridium (77)				
Ir-189 <sup>(a)</sup>	$1 \times 10^1$	$1 \times 10^1$	$1 \times 10^2$	$1 \times 10^7$
Ir-190	$7 \times 10^{-1}$	$7 \times 10^{-1}$	$1 \times 10^1$	$1 \times 10^6$
Ir-192	$1 \times 10^{0(c)}$	$6 \times 10^{-1}$	$1 \times 10^1$	$1 \times 10^4$
Ir-194	$3 \times 10^{-1}$	$3 \times 10^{-1}$	$1 \times 10^2$	$1 \times 10^5$
Potassium (19)				
K-40	$9 \times 10^{-1}$	$9 \times 10^{-1}$	$1 \times 10^2$	$1 \times 10^6$
K-42	$2 \times 10^{-1}$	$2 \times 10^{-1}$	$1 \times 10^2$	$1 \times 10^6$

*Status: This is the original version (as it was originally made).*

(1) Radionuclide (atomic number)	(2) $A_1$  (TBq)	(3) $A_2$  (TBq)	(4) Activity concentration for exempt material (Bq/g)	(5) Activity limit for an exempt consignment (Bq)
K-43	$7 \times 10^{-1}$	$6 \times 10^{-1}$	$1 \times 10^1$	$1 \times 10^6$
Krypton (36)				
Kr-81	$4 \times 10^1$	$4 \times 10^1$	$1 \times 10^4$	$1 \times 10^7$
Kr-85	$1 \times 10^1$	$1 \times 10^1$	$1 \times 10^5$	$1 \times 10^4$
Kr-85m	$8 \times 10^0$	$3 \times 10^0$	$1 \times 10^3$	$1 \times 10^{10}$
Kr-87	$2 \times 10^{-1}$	$2 \times 10^{-1}$	$1 \times 10^2$	$1 \times 10^9$
Lanthanum (57)				
La-137	$3 \times 10^1$	$6 \times 10^0$	$1 \times 10^3$	$1 \times 10^7$
La-140	$4 \times 10^{-1}$	$4 \times 10^{-1}$	$1 \times 10^1$	$1 \times 10^5$
Lutetium (71)				
Lu-172	$6 \times 10^{-1}$	$6 \times 10^{-1}$	$1 \times 10^1$	$1 \times 10^6$
Lu-173	$8 \times 10^0$	$8 \times 10^0$	$1 \times 10^2$	$1 \times 10^7$
Lu-174	$9 \times 10^0$	$9 \times 10^0$	$1 \times 10^2$	$1 \times 10^7$
Lu-174m	$2 \times 10^1$	$1 \times 10^1$	$1 \times 10^2$	$1 \times 10^7$
Lu-177	$3 \times 10^1$	$7 \times 10^{-1}$	$1 \times 10^3$	$1 \times 10^7$
Magnesium (12)				
Mg-28 <sup>(a)</sup>	$3 \times 10^{-1}$	$3 \times 10^{-1}$	$1 \times 10^1$	$1 \times 10^5$
Manganese (25)				
Mn-52	$3 \times 10^{-1}$	$3 \times 10^{-1}$	$1 \times 10^1$	$1 \times 10^5$
Mn-53	Unlimited	Unlimited	$1 \times 10^4$	$1 \times 10^9$
Mn-54	$1 \times 10^0$	$1 \times 10^0$	$1 \times 10^1$	$1 \times 10^6$
Mn-56	$3 \times 10^{-1}$	$3 \times 10^{-1}$	$1 \times 10^1$	$1 \times 10^5$
Molybdenum (42)				
Mo-93	$4 \times 10^1$	$2 \times 10^1$	$1 \times 10^3$	$1 \times 10^8$
Mo-99 <sup>(a)</sup>	$1 \times 10^0$	$6 \times 10^{-1}$	$1 \times 10^2$	$1 \times 10^6$
Nitrogen (7)				
N-13	$9 \times 10^{-1}$	$6 \times 10^{-1}$	$1 \times 10^2$	$1 \times 10^9$
Sodium (11)				

(1) Radionuclide (atomic number)	(2) $A_1$  (TBq)	(3) $A_2$  (TBq)	(4) Activity concentration for exempt material (Bq/g)	(5) Activity limit for an exempt consignment (Bq)
Na-22	$5 \times 10^{-1}$	$5 \times 10^{-1}$	$1 \times 10^1$	$1 \times 10^6$
Na-24	$2 \times 10^{-1}$	$2 \times 10^{-1}$	$1 \times 10^1$	$1 \times 10^5$
Niobium (41)				
Nb-93m	$4 \times 10^1$	$3 \times 10^1$	$1 \times 10^4$	$1 \times 10^7$
Nb-94	$7 \times 10^{-1}$	$7 \times 10^{-1}$	$1 \times 10^1$	$1 \times 10^6$
Nb-95	$1 \times 10^0$	$1 \times 10^0$	$1 \times 10^1$	$1 \times 10^6$
Nb-97	$9 \times 10^{-1}$	$6 \times 10^{-1}$	$1 \times 10^1$	$1 \times 10^6$
Neodymium (60)				
Nd-147	$6 \times 10^0$	$6 \times 10^{-1}$	$1 \times 10^2$	$1 \times 10^6$
Nd-149	$6 \times 10^{-1}$	$5 \times 10^{-1}$	$1 \times 10^2$	$1 \times 10^6$
Nickel (28)				
Ni-59	Unlimited	Unlimited	$1 \times 10^4$	$1 \times 10^8$
Ni-63	$4 \times 10^1$	$3 \times 10^1$	$1 \times 10^5$	$1 \times 10^8$
Ni-65	$4 \times 10^{-1}$	$4 \times 10^{-1}$	$1 \times 10^1$	$1 \times 10^6$
Neptunium (93)				
Np-235	$4 \times 10^1$	$4 \times 10^1$	$1 \times 10^3$	$1 \times 10^7$
Np-236(short-lived)	$2 \times 10^1$	$2 \times 10^0$	$1 \times 10^3$	$1 \times 10^7$
Np-236(long-lived)	$9 \times 10^0$	$2 \times 10^{-2}$	$1 \times 10^2$	$1 \times 10^5$
Np-237	$2 \times 10^1$	$2 \times 10^{-3}$	$1 \times 10^{0(b)}$	$1 \times 10^{3(b)}$
Np-239	$7 \times 10^0$	$4 \times 10^{-1}$	$1 \times 10^2$	$1 \times 10^7$
Osmium (76)				
Os-185	$1 \times 10^0$	$1 \times 10^0$	$1 \times 10^1$	$1 \times 10^6$
Os-191	$1 \times 10^1$	$2 \times 10^0$	$1 \times 10^2$	$1 \times 10^7$
Os-191m	$4 \times 10^1$	$3 \times 10^1$	$1 \times 10^3$	$1 \times 10^7$
Os-193	$2 \times 10^0$	$6 \times 10^{-1}$	$1 \times 10^2$	$1 \times 10^6$
Os-194 <sup>(a)</sup>	$3 \times 10^{-1}$	$3 \times 10^{-1}$	$1 \times 10^2$	$1 \times 10^5$
Phosphorus (15)				

*Status: This is the original version (as it was originally made).*

(1) Radionuclide (atomic number)	(2) $A_1$  (TBq)	(3) $A_2$  (TBq)	(4) Activity concentration for exempt material (Bq/g)	(5) Activity limit for an exempt consignment (Bq)
P-32	$5 \times 10^{-1}$	$5 \times 10^{-1}$	$1 \times 10^3$	$1 \times 10^5$
P-33	$4 \times 10^1$	$1 \times 10^0$	$1 \times 10^5$	$1 \times 10^8$
Protactinium (91)				
Pa-230 <sup>(a)</sup>	$2 \times 10^0$	$7 \times 10^{-2}$	$1 \times 10^1$	$1 \times 10^6$
Pa-231	$4 \times 10^0$	$4 \times 10^{-4}$	$1 \times 10^0$	$1 \times 10^3$
Pa-233	$5 \times 10^0$	$7 \times 10^{-1}$	$1 \times 10^2$	$1 \times 10^7$
Lead (82)				
Pb-201	$1 \times 10^0$	$1 \times 10^0$	$1 \times 10^1$	$1 \times 10^6$
Pb-202	$4 \times 10^1$	$2 \times 10^1$	$1 \times 10^3$	$1 \times 10^6$
Pb-203	$4 \times 10^0$	$3 \times 10^0$	$1 \times 10^2$	$1 \times 10^6$
Pb-205	Unlimited	Unlimited	$1 \times 10^4$	$1 \times 10^7$
Pb-210 <sup>(a)</sup>	$1 \times 10^0$	$5 \times 10^{-2}$	$1 \times 10^{1(b)}$	$1 \times 10^{4(b)}$
Pb-212 <sup>(a)</sup>	$7 \times 10^{-1}$	$2 \times 10^{-1}$	$1 \times 10^{1(b)}$	$1 \times 10^{5(b)}$
Palladium (46)				
Pd-10 <sup>3(a)</sup>	$4 \times 10^1$	$4 \times 10^1$	$1 \times 10^3$	$1 \times 10^8$
Pd-10 <sup>7</sup>	Unlimited	Unlimited	$1 \times 10^5$	$1 \times 10^8$
Pd-10 <sup>9</sup>	$2 \times 10^0$	$5 \times 10^{-1}$	$1 \times 10^3$	$1 \times 10^6$
Promethium (61)				
Pm-143	$3 \times 10^0$	$3 \times 10^0$	$1 \times 10^2$	$1 \times 10^6$
Pm-144	$7 \times 10^{-1}$	$7 \times 10^{-1}$	$1 \times 10^1$	$1 \times 10^6$
Pm-145	$3 \times 10^1$	$1 \times 10^1$	$1 \times 10^3$	$1 \times 10^7$
Pm-147	$4 \times 10^1$	$2 \times 10^0$	$1 \times 10^4$	$1 \times 10^7$
Pm-148m <sup>(a)</sup>	$8 \times 10^{-1}$	$7 \times 10^{-1}$	$1 \times 10^1$	$1 \times 10^6$
Pm-149	$2 \times 10^0$	$6 \times 10^{-1}$	$1 \times 10^3$	$1 \times 10^6$
Pm-151	$2 \times 10^0$	$6 \times 10^{-1}$	$1 \times 10^2$	$1 \times 10^6$
Polonium (84)				
Po-210	$4 \times 10^1$	$2 \times 10^{-2}$	$1 \times 10^1$	$1 \times 10^4$



(1) Radionuclide (atomic number)	(2) $A_1$  (TBq)	(3) $A_2$  (TBq)	(4) Activity concentration for exempt material (Bq/g)	(5) Activity limit for an exempt consignment (Bq)
Praseodymium (59)				
Pr-142	$4 \times 10^{-1}$	$4 \times 10^{-1}$	$1 \times 10^2$	$1 \times 10^5$
Pr-143	$3 \times 10^0$	$6 \times 10^{-1}$	$1 \times 10^4$	$1 \times 10^6$
Platinum (78)				
Pt-188 <sup>(a)</sup>	$1 \times 10^0$	$8 \times 10^{-1}$	$1 \times 10^1$	$1 \times 10^6$
Pt-191	$4 \times 10^0$	$3 \times 10^0$	$1 \times 10^2$	$1 \times 10^6$
Pt-193	$4 \times 10^1$	$4 \times 10^1$	$1 \times 10^4$	$1 \times 10^7$
Pt-193m	$4 \times 10^1$	$5 \times 10^{-1}$	$1 \times 10^3$	$1 \times 10^7$
Pt-195m	$1 \times 10^1$	$5 \times 10^{-1}$	$1 \times 10^2$	$1 \times 10^6$
Pt-197	$2 \times 10^1$	$6 \times 10^{-1}$	$1 \times 10^3$	$1 \times 10^6$
Pt-197m	$1 \times 10^1$	$6 \times 10^{-1}$	$1 \times 10^2$	$1 \times 10^6$
Plutonium (94)				
Pu-236	$3 \times 10^1$	$3 \times 10^{-3}$	$1 \times 10^1$	$1 \times 10^4$
Pu-237	$2 \times 10^1$	$2 \times 10^1$	$1 \times 10^3$	$1 \times 10^7$
Pu-238	$1 \times 10^1$	$1 \times 10^{-3}$	$1 \times 10^0$	$1 \times 10^4$
Pu-239	$1 \times 10^1$	$1 \times 10^{-3}$	$1 \times 10^0$	$1 \times 10^4$
Pu-240	$1 \times 10^1$	$1 \times 10^{-3}$	$1 \times 10^0$	$1 \times 10^3$
Pu-241 <sup>(a)</sup>	$4 \times 10^1$	$6 \times 10^{-2}$	$1 \times 10^2$	$1 \times 10^5$
Pu-242	$1 \times 10^1$	$1 \times 10^{-3}$	$1 \times 10^0$	$1 \times 10^4$
Pu-244 <sup>(a)</sup>	$4 \times 10^{-1}$	$1 \times 10^{-3}$	$1 \times 10^0$	$1 \times 10^4$
Radium (88)				
Ra-223 <sup>(a)</sup>	$4 \times 10^{-1}$	$7 \times 10^{-3}$	$1 \times 10^{2(b)}$	$1 \times 10^{5(b)}$
Ra-224 <sup>(a)</sup>	$4 \times 10^{-1}$	$2 \times 10^{-2}$	$1 \times 10^{1(b)}$	$1 \times 10^{5(b)}$
Ra-225 <sup>(a)</sup>	$2 \times 10^{-1}$	$4 \times 10^{-3}$	$1 \times 10^2$	$1 \times 10^5$
Ra-226 <sup>(a)</sup>	$2 \times 10^{-1}$	$3 \times 10^{-3}$	$1 \times 10^{1(b)}$	$1 \times 10^{4(b)}$
Ra-228 <sup>(a)</sup>	$6 \times 10^{-1}$	$2 \times 10^{-2}$	$1 \times 10^{1(b)}$	$1 \times 10^{5(b)}$
Rubidium (37)				

*Status: This is the original version (as it was originally made).*

(1) Radionuclide (atomic number)	(2) $A_1$  (TBq)	(3) $A_2$  (TBq)	(4) Activity concentration for exempt material (Bq/g)	(5) Activity limit for an exempt consignment (Bq)
Rb-81	$2 \times 10^0$	$8 \times 10^{-1}$	$1 \times 10^1$	$1 \times 10^6$
Rb-83 <sup>(a)</sup>	$2 \times 10^0$	$2 \times 10^0$	$1 \times 10^2$	$1 \times 10^6$
Rb-84	$1 \times 10^0$	$1 \times 10^0$	$1 \times 10^1$	$1 \times 10^6$
Rb-86	$5 \times 10^{-1}$	$5 \times 10^{-1}$	$1 \times 10^2$	$1 \times 10^5$
Rb-87	Unlimited	Unlimited	$1 \times 10^4$	$1 \times 10^7$
Rb(nat)	Unlimited	Unlimited	$1 \times 10^4$	$1 \times 10^7$
Rhenium (75)				
Re-184	$1 \times 10^0$	$1 \times 10^0$	$1 \times 10^1$	$1 \times 10^6$
Re-184m	$3 \times 10^0$	$1 \times 10^0$	$1 \times 10^2$	$1 \times 10^6$
Re-186	$2 \times 10^0$	$6 \times 10^{-1}$	$1 \times 10^3$	$1 \times 10^6$
Re-187	Unlimited	Unlimited	$1 \times 10^6$	$1 \times 10^9$
Re-188	$4 \times 10^{-1}$	$4 \times 10^{-1}$	$1 \times 10^2$	$1 \times 10^5$
Re-189 <sup>(a)</sup>	$3 \times 10^0$	$6 \times 10^{-1}$	$1 \times 10^2$	$1 \times 10^6$
Re(nat)	Unlimited	Unlimited	$1 \times 10^6$	$1 \times 10^9$
Rhodium (45)				
Rh-99	$2 \times 10^0$	$2 \times 10^0$	$1 \times 10^1$	$1 \times 10^6$
Rh-10 <sup>1</sup>	$4 \times 10^0$	$3 \times 10^0$	$1 \times 10^2$	$1 \times 10^7$
Rh-10 <sup>2</sup>	$5 \times 10^{-1}$	$5 \times 10^{-1}$	$1 \times 10^1$	$1 \times 10^6$
Rh-10 <sup>2</sup> m	$2 \times 10^0$	$2 \times 10^0$	$1 \times 10^2$	$1 \times 10^6$
Rh-10 <sup>3</sup> m	$4 \times 10^1$	$4 \times 10^1$	$1 \times 10^4$	$1 \times 10^8$
Rh-10 <sup>5</sup>	$1 \times 10^1$	$8 \times 10^{-1}$	$1 \times 10^2$	$1 \times 10^7$
Radon (86)				
Rn-222 <sup>(a)</sup>	$3 \times 10^{-1}$	$4 \times 10^{-3}$	$1 \times 10^{1(b)}$	$1 \times 10^{8(b)}$
Ruthenium (44)				
Ru-97	$5 \times 10^0$	$5 \times 10^0$	$1 \times 10^2$	$1 \times 10^7$
Ru-10 <sup>3(a)</sup>	$2 \times 10^0$	$2 \times 10^0$	$1 \times 10^2$	$1 \times 10^6$
Ru-10 <sup>5</sup>	$1 \times 10^0$	$6 \times 10^{-1}$	$1 \times 10^1$	$1 \times 10^6$
Ru-10 <sup>6(a)</sup>	$2 \times 10^{-1}$	$2 \times 10^{-1}$	$1 \times 10^{2(b)}$	$1 \times 10^{5(b)}$

(1) Radionuclide (atomic number)	(2) $A_1$  (TBq)	(3) $A_2$  (TBq)	(4) Activity concentration for exempt material (Bq/g)	(5) Activity limit for an exempt consignment (Bq)
Sulphur (16)				
S-35	$4 \times 10^1$	$3 \times 10^0$	$1 \times 10^5$	$1 \times 10^8$
Antimony (51)				
Sb-122	$4 \times 10^{-1}$	$4 \times 10^{-1}$	$1 \times 10^2$	$1 \times 10^4$
Sb-124	$6 \times 10^{-1}$	$6 \times 10^{-1}$	$1 \times 10^1$	$1 \times 10^6$
Sb-125	$2 \times 10^0$	$1 \times 10^0$	$1 \times 10^2$	$1 \times 10^6$
Sb-126	$4 \times 10^{-1}$	$4 \times 10^{-1}$	$1 \times 10^1$	$1 \times 10^5$
Scandium (21)				
Sc-44	$5 \times 10^{-1}$	$5 \times 10^{-1}$	$1 \times 10^1$	$1 \times 10^5$
Sc-46	$5 \times 10^{-1}$	$5 \times 10^{-1}$	$1 \times 10^1$	$1 \times 10^6$
Sc-47	$1 \times 10^1$	$7 \times 10^{-1}$	$1 \times 10^2$	$1 \times 10^6$
Sc-48	$3 \times 10^{-1}$	$3 \times 10^{-1}$	$1 \times 10^1$	$1 \times 10^5$
Selenium (34)				
Se-75	$3 \times 10^0$	$3 \times 10^0$	$1 \times 10^2$	$1 \times 10^6$
Se-79	$4 \times 10^1$	$2 \times 10^0$	$1 \times 10^4$	$1 \times 10^7$
Silicon (14)				
Si-31	$6 \times 10^{-1}$	$6 \times 10^{-1}$	$1 \times 10^3$	$1 \times 10^6$
Si-32	$4 \times 10^1$	$5 \times 10^{-1}$	$1 \times 10^3$	$1 \times 10^6$
Samarium (62)				
Sm-145	$1 \times 10^1$	$1 \times 10^1$	$1 \times 10^2$	$1 \times 10^7$
Sm-147	Unlimited	Unlimited	$1 \times 10^1$	$1 \times 10^4$
Sm-151	$4 \times 10^1$	$1 \times 10^1$	$1 \times 10^4$	$1 \times 10^8$
Sm-153	$9 \times 10^0$	$6 \times 10^{-1}$	$1 \times 10^2$	$1 \times 10^6$
Tin (50)				
Sn-113 <sup>(a)</sup>	$4 \times 10^0$	$2 \times 10^0$	$1 \times 10^3$	$1 \times 10^7$
Sn-117m	$7 \times 10^0$	$4 \times 10^{-1}$	$1 \times 10^2$	$1 \times 10^6$
Sn-119m	$4 \times 10^1$	$3 \times 10^1$	$1 \times 10^3$	$1 \times 10^7$
Sn-121m <sup>(a)</sup>	$4 \times 10^1$	$9 \times 10^{-1}$	$1 \times 10^3$	$1 \times 10^7$

*Status: This is the original version (as it was originally made).*

(1) Radionuclide (atomic number)	(2) $A_1$  (TBq)	(3) $A_2$  (TBq)	(4) Activity concentration for exempt material (Bq/g)	(5) Activity limit for an exempt consignment (Bq)
Sn-123	$8 \times 10^{-1}$	$6 \times 10^{-1}$	$1 \times 10^3$	$1 \times 10^6$
Sn-125	$4 \times 10^{-1}$	$4 \times 10^{-1}$	$1 \times 10^2$	$1 \times 10^5$
Sn-126 <sup>(a)</sup>	$6 \times 10^{-1}$	$4 \times 10^{-1}$	$1 \times 10^1$	$1 \times 10^5$
Strontium (38)				
Sr-82 <sup>(a)</sup>	$2 \times 10^{-1}$	$2 \times 10^{-1}$	$1 \times 10^1$	$1 \times 10^5$
Sr-85	$2 \times 10^0$	$2 \times 10^0$	$1 \times 10^2$	$1 \times 10^6$
Sr-85m	$5 \times 10^0$	$5 \times 10^0$	$1 \times 10^2$	$1 \times 10^7$
Sr-87m	$3 \times 10^0$	$3 \times 10^0$	$1 \times 10^2$	$1 \times 10^6$
Sr-89	$6 \times 10^{-1}$	$6 \times 10^{-1}$	$1 \times 10^3$	$1 \times 10^6$
Sr-90 <sup>(a)</sup>	$3 \times 10^{-1}$	$3 \times 10^{-1}$	$1 \times 10^{2(b)}$	$1 \times 10^{4(b)}$
Sr-91 <sup>(a)</sup>	$3 \times 10^{-1}$	$3 \times 10^{-1}$	$1 \times 10^1$	$1 \times 10^5$
Sr-92 <sup>(a)</sup>	$1 \times 10^0$	$3 \times 10^{-1}$	$1 \times 10^1$	$1 \times 10^6$
Tritium (1)				
T(H-3)	$4 \times 10^1$	$4 \times 10^1$	$1 \times 10^6$	$1 \times 10^9$
Tantalum (73)				
Ta-178(long-lived)	$1 \times 10^0$	$8 \times 10^{-1}$	$1 \times 10^1$	$1 \times 10^6$
Ta-179	$3 \times 10^1$	$3 \times 10^1$	$1 \times 10^3$	$1 \times 10^7$
Ta-182	$9 \times 10^{-1}$	$5 \times 10^{-1}$	$1 \times 10^1$	$1 \times 10^4$
Terbium (65)				
Tb-157	$4 \times 10^1$	$4 \times 10^1$	$1 \times 10^4$	$1 \times 10^7$
Tb-158	$1 \times 10^0$	$1 \times 10^0$	$1 \times 10^1$	$1 \times 10^6$
Tb-160	$1 \times 10^0$	$6 \times 10^{-1}$	$1 \times 10^1$	$1 \times 10^6$
Technetium (43)				
Tc-95m <sup>(a)</sup>	$2 \times 10^0$	$2 \times 10^0$	$1 \times 10^1$	$1 \times 10^6$
Tc-96	$4 \times 10^{-1}$	$4 \times 10^{-1}$	$1 \times 10^1$	$1 \times 10^6$
Tc-96m <sup>(a)</sup>	$4 \times 10^{-1}$	$4 \times 10^{-1}$	$1 \times 10^3$	$1 \times 10^7$
Tc-97	Unlimited	Unlimited	$1 \times 10^3$	$1 \times 10^8$

(1) Radionuclide (atomic number)	(2) $A_1$  (TBq)	(3) $A_2$  (TBq)	(4) Activity concentration for exempt material (Bq/g)	(5) Activity limit for an exempt consignment (Bq)
Tc-97m	$4 \times 10^1$	$1 \times 10^0$	$1 \times 10^3$	$1 \times 10^7$
Tc-98	$8 \times 10^{-1}$	$7 \times 10^{-1}$	$1 \times 10^1$	$1 \times 10^6$
Tc-99	$4 \times 10^1$	$9 \times 10^{-1}$	$1 \times 10^4$	$1 \times 10^7$
Tc-99m	$1 \times 10^1$	$4 \times 10^0$	$1 \times 10^2$	$1 \times 10^7$
Tellurium (52)				
Te-121	$2 \times 10^0$	$2 \times 10^0$	$1 \times 10^1$	$1 \times 10^6$
Te-121m	$5 \times 10^0$	$3 \times 10^0$	$1 \times 10^2$	$1 \times 10^5$
Te-123m	$8 \times 10^0$	$1 \times 10^0$	$1 \times 10^2$	$1 \times 10^7$
Te-125m	$2 \times 10^1$	$9 \times 10^{-1}$	$1 \times 10^3$	$1 \times 10^7$
Te-127	$2 \times 10^1$	$7 \times 10^{-1}$	$1 \times 10^3$	$1 \times 10^6$
Te-127m <sup>(a)</sup>	$2 \times 10^1$	$5 \times 10^{-1}$	$1 \times 10^3$	$1 \times 10^7$
Te-129	$7 \times 10^{-1}$	$6 \times 10^{-1}$	$1 \times 10^2$	$1 \times 10^6$
Te-129m <sup>(a)</sup>	$8 \times 10^{-1}$	$4 \times 10^{-1}$	$1 \times 10^3$	$1 \times 10^6$
Te-131m <sup>(a)</sup>	$7 \times 10^{-1}$	$5 \times 10^{-1}$	$1 \times 10^1$	$1 \times 10^6$
Te-132 <sup>(a)</sup>	$5 \times 10^{-1}$	$4 \times 10^{-1}$	$1 \times 10^2$	$1 \times 10^7$
Thorium (90)				
Th-227	$1 \times 10^1$	$5 \times 10^{-3}$	$1 \times 10^1$	$1 \times 10^4$
Th-228 <sup>(a)</sup>	$5 \times 10^{-1}$	$1 \times 10^{-3}$	$1 \times 10^{0(b)}$	$1 \times 10^{4(b)}$
Th-229	$5 \times 10^0$	$5 \times 10^{-4}$	$1 \times 10^{0(b)}$	$1 \times 10^{3(b)}$
Th-230	$1 \times 10^1$	$1 \times 10^{-3}$	$1 \times 10^0$	$1 \times 10^4$
Th-231	$4 \times 10^1$	$2 \times 10^{-2}$	$1 \times 10^3$	$1 \times 10^7$
Th-232	Unlimited	Unlimited	$1 \times 10^1$	$1 \times 10^4$
Th-234 <sup>(a)</sup>	$3 \times 10^{-1}$	$3 \times 10^{-1}$	$1 \times 10^{3(b)}$	$1 \times 10^{5(b)}$
Th(nat)	Unlimited	Unlimited	$1 \times 10^{0(b)}$	$1 \times 10^{3(b)}$
Titanium (22)				
Ti-44 <sup>(a)</sup>	$5 \times 10^{-1}$	$4 \times 10^{-1}$	$1 \times 10^1$	$1 \times 10^5$
Thallium (81)				
Tl-200	$9 \times 10^{-1}$	$9 \times 10^{-1}$	$1 \times 10^1$	$1 \times 10^6$

*Status: This is the original version (as it was originally made).*

(1) Radionuclide (atomic number)	(2) $A_1$  (TBq)	(3) $A_2$  (TBq)	(4) Activity concentration for exempt material (Bq/g)	(5) Activity limit for an exempt consignment (Bq)
Tl-201	$1 \times 10^1$	$4 \times 10^0$	$1 \times 10^2$	$1 \times 10^6$
Tl-202	$2 \times 10^0$	$2 \times 10^0$	$1 \times 10^2$	$1 \times 10^6$
Tl-204	$1 \times 10^1$	$7 \times 10^{-1}$	$1 \times 10^4$	$1 \times 10^4$
Thulium (69)				
Tm-167	$7 \times 10^0$	$8 \times 10^{-1}$	$1 \times 10^2$	$1 \times 10^6$
Tm-170	$3 \times 10^0$	$6 \times 10^{-1}$	$1 \times 10^3$	$1 \times 10^6$
Tm-171	$4 \times 10^1$	$4 \times 10^1$	$1 \times 10^4$	$1 \times 10^8$
Uranium (92)				
U-230 (fast lung absorption) <sup>(a)(d)</sup>	$4 \times 10^1$	$1 \times 10^{-1}$	$1 \times 10^{1(b)}$	$1 \times 10^{5(b)}$
U-230 (medium lung absorption) <sup>(a)(e)</sup>	$4 \times 10^1$	$4 \times 10^{-3}$	$1 \times 10^1$	$1 \times 10^4$
U-230 (slow lung absorption) <sup>(a)(f)</sup>	$3 \times 10^1$	$3 \times 10^{-3}$	$1 \times 10^1$	$1 \times 10^4$
U-232 (fast lung absorption) <sup>(d)</sup>	$4 \times 10^1$	$1 \times 10^{-2}$	$1 \times 10^{0(b)}$	$1 \times 10^{3(b)}$
U-232 (medium lung absorption) <sup>(e)</sup>	$4 \times 10^1$	$7 \times 10^{-3}$	$1 \times 10^1$	$1 \times 10^4$
U-232 (slow lung absorption) <sup>(f)</sup>	$1 \times 10^1$	$1 \times 10^{-3}$	$1 \times 10^1$	$1 \times 10^4$
U-233 (fast lung absorption) <sup>(d)</sup>	$4 \times 10^1$	$9 \times 10^{-2}$	$1 \times 10^1$	$1 \times 10^4$
U-233 (medium lung absorption) <sup>(e)</sup>	$4 \times 10^1$	$2 \times 10^{-2}$	$1 \times 10^2$	$1 \times 10^5$
U-233 (slow lung absorption) <sup>(f)</sup>	$4 \times 10^1$	$6 \times 10^{-3}$	$1 \times 10^1$	$1 \times 10^5$
U-234 (fast lung absorption) <sup>(d)</sup>	$4 \times 10^1$	$9 \times 10^{-2}$	$1 \times 10^1$	$1 \times 10^4$
U-234 (medium lung absorption) <sup>(e)</sup>	$4 \times 10^1$	$2 \times 10^{-2}$	$1 \times 10^2$	$1 \times 10^5$
U-234 (slow lung absorption) <sup>(f)</sup>	$4 \times 10^1$	$6 \times 10^{-3}$	$1 \times 10^1$	$1 \times 10^5$

(1) Radionuclide (atomic number)	(2) $A_1$  (TBq)	(3) $A_2$  (TBq)	(4) Activity concentration for exempt material (Bq/g)	(5) Activity limit for an exempt consignment (Bq)
U-235 (all lung absorption types) <sup>(a)(d)(e)(f)</sup>	Unlimited	Unlimited	$1 \times 10^{1(b)}$	$1 \times 10^{4(b)}$
U-236 (fast lung absorption) <sup>(d)</sup>	Unlimited	Unlimited	$1 \times 10^1$	$1 \times 10^4$
U-236 (medium lung absorption) <sup>(e)</sup>	$4 \times 10^1$	$2 \times 10^{-2}$	$1 \times 10^2$	$1 \times 10^5$
U-236 (slow lung absorption) <sup>(f)</sup>	$4 \times 10^1$	$6 \times 10^{-3}$	$1 \times 10^1$	$1 \times 10^4$
U-238 (all lung absorption types) <sup>(d)(e)(f)</sup>	Unlimited	Unlimited	$1 \times 10^{1(b)}$	$1 \times 10^{4(b)}$
U (nat)	Unlimited	Unlimited	$1 \times 10^{0(b)}$	$1 \times 10^{3(b)}$
U (enriched to 20% or less) <sup>(g)</sup>	Unlimited	Unlimited	$1 \times 10^0$	$1 \times 10^3$
U (dep)	Unlimited	Unlimited	$1 \times 10^0$	$1 \times 10^3$
Vanadium (23)				
V-48	$4 \times 10^{-1}$	$4 \times 10^{-1}$	$1 \times 10^1$	$1 \times 10^5$
V-49	$4 \times 10^1$	$4 \times 10^1$	$1 \times 10^4$	$1 \times 10^7$
Tungsten (74)				
W-178 <sup>(a)</sup>	$9 \times 10^0$	$5 \times 10^0$	$1 \times 10^1$	$1 \times 10^6$
W-181	$3 \times 10^1$	$3 \times 10^1$	$1 \times 10^3$	$1 \times 10^7$
W-185	$4 \times 10^1$	$8 \times 10^{-1}$	$1 \times 10^4$	$1 \times 10^7$
W-187	$2 \times 10^0$	$6 \times 10^{-1}$	$1 \times 10^2$	$1 \times 10^6$
W-188 <sup>(a)</sup>	$4 \times 10^{-1}$	$3 \times 10^{-1}$	$1 \times 10^2$	$1 \times 10^5$
Xenon (54)				
Xe-122 <sup>(a)</sup>	$4 \times 10^{-1}$	$4 \times 10^{-1}$	$1 \times 10^2$	$1 \times 10^9$
Xe-123	$2 \times 10^0$	$7 \times 10^{-1}$	$1 \times 10^2$	$1 \times 10^9$
Xe-127	$4 \times 10^0$	$2 \times 10^0$	$1 \times 10^3$	$1 \times 10^5$
Xe-131m	$4 \times 10^1$	$4 \times 10^1$	$1 \times 10^4$	$1 \times 10^4$
Xe-133	$2 \times 10^1$	$1 \times 10^1$	$1 \times 10^3$	$1 \times 10^4$

**Status:** This is the original version (as it was originally made).

(1) Radionuclide (atomic number)	(2) $A_1$  (TBq)	(3) $A_2$  (TBq)	(4) Activity concentration for exempt material (Bq/g)	(5) Activity limit for an exempt consignment (Bq)
Xe-135	$3 \times 10^0$	$2 \times 10^0$	$1 \times 10^3$	$1 \times 10^{10}$
Yttrium (39)				
Y-87 <sup>(a)</sup>	$1 \times 10^0$	$1 \times 10^0$	$1 \times 10^1$	$1 \times 10^6$
Y-88	$4 \times 10^{-1}$	$4 \times 10^{-1}$	$1 \times 10^1$	$1 \times 10^6$
Y-90	$3 \times 10^{-1}$	$3 \times 10^{-1}$	$1 \times 10^3$	$1 \times 10^5$
Y-91	$6 \times 10^{-1}$	$6 \times 10^{-1}$	$1 \times 10^3$	$1 \times 10^6$
Y-91m	$2 \times 10^0$	$2 \times 10^0$	$1 \times 10^2$	$1 \times 10^6$
Y-92	$2 \times 10^{-1}$	$2 \times 10^{-1}$	$1 \times 10^2$	$1 \times 10^5$
Y-93	$3 \times 10^{-1}$	$3 \times 10^{-1}$	$1 \times 10^2$	$1 \times 10^5$
Ytterbium (79)				
Yb-169	$4 \times 10^0$	$1 \times 10^0$	$1 \times 10^2$	$1 \times 10^7$
Yb-175	$3 \times 10^1$	$9 \times 10^{-1}$	$1 \times 10^3$	$1 \times 10^7$
Zinc (30)				
Zn-65	$2 \times 10^0$	$2 \times 10^0$	$1 \times 10^1$	$1 \times 10^6$
Zn-69	$3 \times 10^0$	$6 \times 10^{-1}$	$1 \times 10^4$	$1 \times 10^6$
Zn-69m <sup>(a)</sup>	$3 \times 10^0$	$6 \times 10^{-1}$	$1 \times 10^2$	$1 \times 10^6$
Zirconium (40)				
Zr-88	$3 \times 10^0$	$3 \times 10^0$	$1 \times 10^2$	$1 \times 10^6$
Zr-93	Unlimited	Unlimited	$1 \times 10^{3(b)}$	$1 \times 10^{7(b)}$
Zr-95 <sup>(a)</sup>	$2 \times 10^0$	$8 \times 10^{-1}$	$1 \times 10^1$	$1 \times 10^6$
Zr-97 <sup>(a)</sup>	$4 \times 10^{-1}$	$4 \times 10^{-1}$	$1 \times 10^{1(b)}$	$1 \times 10^{5(b)}$

(a)  $A_1$  and/or  $A_2$  values include contributions from daughter nuclides with half-lives less than 10 days

(b) Parent nuclides and their progeny included in secular equilibrium are listed in the following—

Sr-90	Y-90
Zr-93	Nb-93m
Zr-97	Nb-97
Ru-10 <sup>6</sup>	Rh-10 <sup>6</sup>
Cs-137	Ba-137m
Ce-134	La-134



**Status:** This is the original version (as it was originally made).

Ce-144	Pr-144
Ba-140	La-140
Bi-212	Tl-208 (0.36), Po-212 (0.64)
Pb-210	Bi-210, Po-210
Pb-212	Bi-212, Tl-208 (0.36), Po-212 (0.64)
Rn-220	Po-216
Rn-222	Po-218, Pb-214, Bi-214, Po-214
Ra-223	Rn-219, Po-215, Pb-211, Bi-211, Tl-207
Th-nat	Ra-228, Ac-228, Th-228, Ra-224, Rn-220, Po-216, Pb-212, Bi-212, Tl-208 (0.36), Po-212 (0.64)
Th-234	Pa-234m
U-230	Th-226, Ra-222, Rn-218, Po-214
U-232	Th-228, Ra-224, Rn-220, Po-216, Pb-212, Bi-212, Tl-208 (0.36), Po-212 (0.64)
U-235	Th-231
U-238	Th-234, Pa-234m
U-nat	Th-234, Pa-234m, U-234, Th-230, Ra-226, Rn-222, Po-218, Pb-214, Bi-214, Po-214, Pb-210, Bi-210, Po-210
U-240	Np-240m
Np-237	Pa-233
Am-242m	Am-242
Am-243	Np-239

- (c) The quantity may be determined from a measurement of the rate of decay or a measurement of the radiation level at a prescribed distance from the source.
- (d) These values apply only to compounds of uranium that take the chemical form of UF<sub>6</sub>, UO<sub>2</sub>F<sub>2</sub> and UO<sub>2</sub>(NO<sub>3</sub>)<sub>2</sub> in both normal and accident conditions of transport.
- (e) These values apply only to compounds of uranium that take the chemical form of UO<sub>3</sub>, UF<sub>4</sub>, UCl<sub>4</sub> and hexavalent compounds in both normal and accident conditions of transport.
- (f) These values apply to all compounds of uranium other than those specified in (d) and (e) above.
- (g) These values apply to unirradiated uranium only.

**TABLE II**

## Basic Radionuclide Values For Unknown Radionuclides or Mixtures

(1) Radioactive contents	(2) $A_1$	(3) $A_2$	(4) Activity concentration for exempt material Bq/g	(5) Activity limits for an exempt consignment Bq
Only beta or gamma emitting nuclides are known to be present	0.1	0.02	$1 \times 10^1$	$1 \times 10^4$

**Status:** This is the original version (as it was originally made).

(1) Radioactive contents	(2) $A_1$	(3) $A_2$	(4) Activity concentration for exempt material Bq/g	(5) Activity limits for an exempt consignment Bq
	TBq	TBq		
Only alpha emitting nuclides are known to be present	0.2	$9 \times 10^{-5}$	$1 \times 10^{-1}$	$1 \times 10^3$
No relevant data are available	0.001	$9 \times 10^{-5}$	$1 \times 10^{-1}$	$1 \times 10^3$

**TABLE III**

ACTIVITY LIMITS FOR EXCEPTED PACKAGES

(1) Physical state of contents	(2) Instrument or article Item limits <sup>a</sup>	(3) Package limits <sup>a</sup>	(4) Materials Package limits <sup>a</sup>
Solids:			
special form	$10^{-2} A_1$	$A_1$	$10^{-3} A_1$
other forms	$10^{-2} A_2$	$A_2$	$10^{-3} A_2$
Liquids	$10^{-3} A_2$	$10^{-1} A_2$	$10^{-4} A_2$
Gases:			
tritium	$2 \times 10^{-2} A_2$	$2 \times 10^{-1} A_2$	$2 \times 10^{-2} A_2$
special form	$10^{-3} A_1$	$10^{-2} A_1$	$10^{-3} A_1$
other forms	$10^{-3} A_2$	$10^{-2} A_2$	$10^{-3} A_2$

**a** For mixtures of radionuclides, see regulation 29(4) and (5)

**TABLE IV**

INDUSTRIAL PACKAGE REQUIREMENTS FOR LSA MATERIAL AND SCO

(1) Radioactive contents	(2) Industrial package type Exclusive use	(3) Not under exclusive use
LSA-I		
Solid <sup>a</sup>	Type IP-1	Type IP-1
Liquid	Type IP-1	Type IP-2

**a** Under the conditions specified in regulation 43 (3), LSA-I material and SCO-I may be transported unpackaged.

**Status:** This is the original version (as it was originally made).

<i>(1)</i> <i>Radioactive contents</i>	<i>(2)</i> <i>Industrial package type</i> <i>Exclusive use</i>	<i>(3)</i> <i>Not under exclusive use</i>
LSA-II		
Solid	Type IP-2	Type IP-2
Liquid and gas	Type IP-2	Type IP-3
LSA-III	Type IP-2	Type IP-3
SCO-I <sup>a</sup>	Type IP-1	Type IP-1
SCO-II	Type IP-2	Type IP-2

**a** Under the conditions specified in regulation 43 (3), LSA-I material and SCO-I may be transported unpackaged.

**TABLE V**

VEHICLE ACTIVITY LIMITS FOR LSA MATERIAL AND  
SCO IN INDUSTRIAL PACKAGES OR UNPACKAGED

<i>(1)</i> <i>Nature of material</i>	<i>(2)</i> <i>Activity limit for vehicles</i>
LSA-I	No limit
LSA-II and LSA-III non-combustible solids	No limit
LSA-II and LSA-III combustible solids, and all liquids and gases	100 A <sub>2</sub>
SCO	100 A <sub>2</sub>

**TABLE VI**

MULTIPLICATION FACTORS FOR LARGE DIMENSION LOADS

<i>(1)</i> <i>Size of load<sup>a</sup></i>	<i>(2)</i> <i>Multiplication factor</i>
size of load ≤ 1 m <sup>2</sup>	1
1 m <sup>2</sup> < size of load ≤ 5 m <sup>2</sup>	2
5 m <sup>2</sup> < size of load ≤ 20 m <sup>2</sup>	3
20 m <sup>2</sup> < size of load	10

**a** Largest cross-sectional area of the load being measured.

**Status:** This is the original version (as it was originally made).

**TABLE VII**

## CATEGORIES OF PACKAGES AND OVERPACKS

<i>(1)</i> <i>Conditions</i> <i>Transport index</i>	<i>(2)</i> <i>Maximum radiation level at</i> <i>any point on external surface</i>	<i>(3)</i> <i>Category</i>
0 <sup>a</sup>	More than 0.005 mSv/h	I-WHITE
More than 0 but not more than 1()	More than 0.005 mSv/h but not more than 0.5 mSv/h	II-YELLOW
More than 1 but not more than 10	More than 0.5 mSv/h but not more than 2 mSv/h	III-YELLOW
More than 10	More than 2 mSv/h but not more than 10 mSv/h	III-YELLOW
		Under exclusive use

**a** If the measured TI is not greater than 0.05, the value quoted may be zero in accordance with paragraph 1(c) of Schedule 5.

**TABLE VIII**

## EXCERPTS FROM LIST OF UNITED NATIONS NUMBERS, PROPER SHIPPING NAME AND DESCRIPTION AND SUBSIDIARY RISKS

<i>(1)</i> <i>UN NO.</i>	<i>(2)</i> <i>PROPER SHIPPING NAME <sup>a</sup></i>	<i>(3)</i> <i>Subsidiary risks</i>
2910	RADIOACTIVE MATERIAL, EXCEPTED PACKAGE	
	— LIMITED QUANTITY OF MATERIAL	
2911	RADIOACTIVE MATERIAL, EXCEPTED PACKAGE	
	— INSTRUMENTS or ARTICLES	
2909	RADIOACTIVE MATERIAL, EXCEPTED PACKAGE	
	— ARTICLES MANUFACTURED FROM NATURAL URANIUM or	

**a** The “PROPER SHIPPING NAME” is found in the column “PROPER SHIPPING NAME and description” and is restricted to that part shown in CAPITAL LETTERS. In the case of UN 2909, UN 2911, UN 2913 and UN 3326 where alternative PROPER SHIPPING NAMES are separated by the word “or”, only the relevant PROPER SHIPPING NAME shall be used.

**b** “Fissile-excepted” applies only to those packages complying with Schedule 8 Part XIV paragraph 3.

**Status:** This is the original version (as it was originally made).

(1) UN NO.	(2) PROPER SHIPPING NAME <sup>a</sup>	(3) Subsidiary risks
	DEPLETED URANIUM or NATURAL THORIUM	
2908	RADIOACTIVE MATERIAL, EXCEPTED PACKAGE	
	— EMPTY PACKAGING	
2912	RADIOACTIVE MATERIAL, LOW SPECIFIC ACTIVITY (LSA-I) non fissile or fissile- excepted <sup>b</sup>	
3321	RADIOACTIVE MATERIAL, LOW SPECIFIC ACTIVITY (LSA-II) non fissile or fissile- excepted <sup>b</sup>	
3322	RADIOACTIVE MATERIAL, LOW SPECIFIC ACTIVITY (LSA-III) non fissile or fissile- excepted <sup>b</sup>	
2913	RADIOACTIVE MATERIAL, SURFACE CONTAMINATED OBJECTS (SCO-I or SCO-II) non fissile or fissile-excepted <sup>b</sup>	
2915	RADIOACTIVE MATERIAL, TYPE A PACKAGE, non- special form, non fissile or fissile-excepted <sup>b</sup>	
3332	RADIOACTIVE MATERIAL, TYPE A PACKAGE, SPECIAL FORM non fissile or fissile-excepted <sup>b</sup>	
2916	RADIOACTIVE MATERIAL, TYPE B(U) PACKAGE, non fissile or fissile-excepted <sup>b</sup>	
2917	RADIOACTIVE MATERIAL, TYPE B(M) PACKAGE, non fissile or fissile-excepted <sup>b</sup>	
3323	RADIOACTIVE MATERIAL, TYPE C PACKAGE, non fissile or fissile-excepted <sup>b</sup>	

**a** The “PROPER SHIPPING NAME” is found in the column “PROPER SHIPPING NAME and description” and is restricted to that part shown in CAPITAL LETTERS. In the case of UN 2909, UN 2911, UN 2913 and UN 3326 where alternative PROPER SHIPPING NAMES are separated by the word “or”, only the relevant PROPER SHIPPING NAME shall be used.

**b** “Fissile-excepted” applies only to those packages complying with Schedule 8 Part XIV paragraph 3.

**Status:** This is the original version (as it was originally made).

(1) UN NO.	(2) PROPER SHIPPING NAME <sup>a</sup>	(3) Subsidiary risks
2919	RADIOACTIVE MATERIAL, TRANSPORTED UNDER SPECIAL ARRANGEMENT, non fissile or fissile-excepted <sup>b</sup>	
2978	RADIOACTIVE MATERIAL, URANIUM HEXAFLUORIDE non fissile or fissile-excepted <sup>b</sup>	corrosive  (UN Class 8)
3324	RADIOACTIVE MATERIAL, LOW SPECIFIC ACTIVITY (LSA-II), FISSILE	
3325	RADIOACTIVE MATERIAL, LOW SPECIFIC ACTIVITY (LSA-III), FISSILE	
3326	RADIOACTIVE MATERIAL, SURFACE CONTAMINATED OBJECTS (SCO-I or SCO-II) FISSILE	
3327	RADIOACTIVE MATERIAL, TYPE A PACKAGE, FISSILE non-special form	
3333	RADIOACTIVE MATERIAL, TYPE A PACKAGE, SPECIAL FORM, FISSILE	
3328	RADIOACTIVE MATERIAL, TYPE B(U) PACKAGE, FISSILE	
3329	RADIOACTIVE MATERIAL, TYPE B(M) PACKAGE, FISSILE	
3330	RADIOACTIVE MATERIAL, TYPE C PACKAGE, FISSILE	
3331	RADIOACTIVE MATERIAL, TRANSPORTED UNDER SPECIAL ARRANGEMENT, FISSILE	
2977	RADIOACTIVE MATERIAL, URANIUM HEXAFLUORIDE, FISSILE	corrosive  (UN Class 8)

**a** The “PROPER SHIPPING NAME” is found in the column “PROPER SHIPPING NAME and description” and is restricted to that part shown in CAPITAL LETTERS. In the case of UN 2909, UN 2911, UN 2913 and UN 3326 where alternative PROPER SHIPPING NAMES are separated by the word “or”, only the relevant PROPER SHIPPING NAME shall be used.

**b** “Fissile-excepted” applies only to those packages complying with Schedule 8 Part XIV paragraph 3.

**TABLE IX**  
INSOLATION DATA

<i>(1)</i> <i>Form and location of surface</i>	<i>(2)</i> <i>Insolation in W/m<sup>2</sup> for 12 hours per day</i>
Flat surfaces transported horizontally:	
–base	none
–other surfaces	800
Flat surfaces not transported horizontally:	200 <sup>a</sup>
–each surface	
Curved surfaces	400 <sup>a</sup>

**a** Alternatively, a sine function may be used, with an absorption coefficient adopted and the effects of possible reflection from neighbouring objects neglected.

**TABLE X**  
CONSIGNMENT MASS LIMITS FOR EXCEPTIONS FROM THE  
REQUIREMENTS FOR PACKAGES CONTAINING FISSILE MATERIAL

<i>(1)</i> <i>Fissile material</i>	<i>(2)</i> <i>Fissile material mass (g) mixed with substances having an average hydrogen density less than or equal to water</i>	<i>(3)</i> <i>Fissile material mass (g) mixed with substances having an average hydrogen density greater than water</i>
Uranium-235 (X)	400	290
Other fissile material (Y)	250	180

**TABLE XI**  
FREE-DROP DISTANCE FOR TESTING PACKAGES  
TO NORMAL CONDITIONS OF TRANSPORT

<i>(1)</i> <i>package mass (kg)</i>	<i>(2)</i> <i>Free-drop distance (m)</i>
package mass < 5,000	1.2
5,000 ≤ package mass < 10,000	0.9
10,000 ≤ package mass < 15,000	0.6
15,000 ≤ package mass	0.3

Status: This is the original version (as it was originally made).

**TABLE XII**

MINIMUM DISTANCES BETWEEN PACKAGES OF CATEGORY II-YELLOW OR OF CATEGORY III-YELLOW AND PERSONS

(1) <i>Sum of transport indexes not more than</i>	(2) <i>Exposure time per year Areas where members of the public have regular access</i>		(3) <i>250 hours</i>		(4) <i>50 hours</i>		(5) <i>Regularly occupied working areas</i>	
	<i>50 hours</i>	<i>250 hours</i>	<i>50 hours</i>	<i>250 hours</i>				
	<i>Segregation distance in metres, no shielding material intervening, from:</i>							
2	1	3	0.5	1				
4	1.5	4	0.5	1.5				
8	2.5	6	1.0	2.5				
12	3	7.5	1.0	3				
20	4	9.5	1.5	4				
30	5	12	2	5				
40	5.5	13.5	2.5	5.5				
50	6.5	15.5	3	6.5				

**TABLE XIII**

MINIMUM DISTANCES BETWEEN PACKAGES OF CATEGORY II-YELLOW OR OF CATEGORY III-YELLOW AND PACKAGES BEARING THE WORD “FOTO”, OR MAILBAGS

(1) <i>Total number of packages not more than</i>	(2) <i>Sum of transport indexes not more than</i>	(3) <i>Journey or storage duration, in hours</i>							
		<i>1</i>	<i>2</i>	<i>4</i>	<i>10</i>	<i>24</i>	<i>48</i>	<i>120</i>	<i>240</i>
<i>Category</i>		<i>Minimum distances in metres</i>							
<i>III-yellow</i>		0.2	0.5	0.5	1	1		2	3
<i>II-yellow</i>		0.5	0.5	0.5	0.5	1	1	2	3
	1	1	0.5	0.5	1	1	2	3	5
	2	2	0.5	1	1	1.5	3	4	7
	4	4	1	1	1.5	3	4	6	9
	8	8	1	1.5	2	4	6	8	13



(1) Total number of packages not more than		(2) Sum of transport indexes not more than	(3) Journey or storage duration, in hours							
Category			1	2	4	10	24	48	120	240
III-yellow	II-yellow		Minimum distances in metres							
1	10	10	1	2	3	4	7	9	14	20
2	20	20	1.5	3	4	6	9	13	20	30
3	30	30	2	3	5	7	11	16	25	35
4	40	40	3	4	5	8	13	18	30	40
5	50	50	3	4	6	9	14	20	32	45

SCHEDULE 2

Regulation 29(3)

A<sub>1</sub> AND A<sub>2</sub> VALUES FOR UNSPECIFIED RADIONUCLIDES

In the calculations of A<sub>1</sub> and A<sub>2</sub> for a radionuclide not in Table I of Schedule 1, a single radioactive decay chain in which the radionuclides are present in their naturally occurring proportions and in which no daughter nuclide has a half-life either longer than 10 days or longer than that of the parent nuclide shall be considered as a single radionuclide, and the activity to be taken into account and the A<sub>1</sub> or A<sub>2</sub> value to be applied must be those corresponding to the parent nuclide of that chain. In the case of radioactive decay chains in which any daughter nuclide has a half-life either longer than 10 days or greater than that of the parent nuclide, the parent and such daughter nuclides must be considered as mixtures of different nuclides.

SCHEDULE 3

Regulation 29(4)

A<sub>1</sub> AND A<sub>2</sub> VALUES FOR MIXTURES OF RADIONUCLIDES

1. For a mixture of radionuclides whose identities and respective activities are known the basic radionuclide values given in Table 1 of Schedule 1 may be determined as follows—

$$X_{\text{m}} = \frac{1}{\sum_i \frac{f(i)}{X(i)}}$$

where

- f(i) is the fraction of activity or activity concentration of radionuclide i in the mixture;
- X(i) is the value of A<sub>1</sub> or A<sub>2</sub>, or the activity concentration for exempt material or the activity limit for an exempt consignment as appropriate for the radionuclide i; and

**Status:** This is the original version (as it was originally made).

$X_m$  is the derived value of  $A_1$  or  $A_2$ , or the activity concentration for exempt material or the activity limit for an exempt consignment in the case of a mixture.

2. When the identity of each radionuclide is known but the individual activities of some of the radionuclides are not known, the radionuclides may be grouped and the lowest radionuclide value, as appropriate, for the radionuclides in each group may be used in applying the formulae in paragraph 1 above and paragraph 4(b) of Schedule 4. Groups may be based on the total alpha activity and the total beta/gamma activity when these are known, using the lowest radionuclide values for the alpha emitters or beta/gamma emitters, respectively.

## SCHEDULE 4

Regulation 30(2)

### CONTENTS LIMITS FOR PACKAGES

#### Excepted packages

1. An excepted package containing radioactive material other than articles manufactured of natural uranium, depleted uranium, or natural thorium must not contain activities greater than the following—

- (a) where the radioactive material is enclosed in or is included as a component part of an instrument or other manufactured article, such as a clock or electronic apparatus, the limits specified in columns 2 and 3 of Table III in Schedule 1 for each individual item and each package respectively; and
- (b) where the radioactive material is not so enclosed or is not included as a component of an instrument or other manufactured article, the package limits specified in column 4 of Table III in Schedule 1.

2. An excepted package containing articles manufactured of natural uranium, depleted uranium, or natural thorium may contain any quantity of such material provided that the outer surface of the uranium or thorium is enclosed in an inactive sheath made of metal or some other substantial material.

#### Industrial packages

3. The radioactive contents in a single package of LSA material or in a single package of SCO must be so restricted that the radiation level specified in regulation 43(2) must not be exceeded, and the activity in a single package must also be so restricted that the activity limits for a vehicle specified in column 2 of Table V of Schedule 1 must not be exceeded.

#### Type A packages

4. A Type A package must not contain activities greater than the following—

- (a) for a Type A package containing a single radionuclide:
  - (i) for special form radioactive material :  $A_1$  ; or
  - (ii) for all other radioactive material :  $A_2$ .
- (b) for a Type A package containing a mixture of radionuclides whose identities and respective activities are known the following formula must apply—

$$\sum_i \frac{B(i)}{A_1(i)} + \sum_j \frac{C(j)}{A_2(j)} \leq 1$$

where:

B(i) is the activity of radionuclide i as special form radioactive material;

A<sub>1</sub>(i) is the A<sub>1</sub> value for radionuclide i;

C(j) is the activity of radionuclide j as other than special form radioactive material;  
and

A<sub>2</sub>(j) is the A<sub>2</sub> value for radionuclide j.

Paragraph 2 of Schedule 3 is also applicable.

### **Type B(U), Type B(M) and Type C packages**

5. A Type B(U), Type B(M) or Type C package must not contain:

- (a) activities greater than those authorised for the package design;
- (b) radionuclides different from those authorised for the package design; or
- (c) contents in a form, or a physical or chemical state different from those authorised for the package design,

as specified in the package design approval certificate.

### **Packages containing fissile material**

6. Packages containing fissile material, other than a package falling within paragraph 3 of Part XIV of Schedule 8, must not contain—

- (a) a mass of fissile material different from that authorised for the package design,
- (b) any contents different from those authorised for the package design, or
- (c) contents in a form or physical or chemical state, or in a spatial arrangement, different from those authorised for the package design,

as specified in the package design approval certificate.

### **Packages containing uranium hexafluoride**

7. The mass of uranium hexafluoride in a package must not exceed a value that would lead to an ullage smaller than 5% at the maximum temperature of the package as specified for the plant systems where the package must be used. The uranium hexafluoride must be in solid form and the internal pressure of the package must be below atmospheric pressure when presented for transport.

### **Special arrangement transport operations**

8. A special arrangement transport operation must not contain—

- (a) activities greater than those authorised for the special arrangement transport operation;
- (b) radionuclides different from those authorised for the special arrangement transport operation; or
- (c) contents in a form, or a physical or chemical state, or in a spatial arrangement different from those authorised for the special arrangement transport operation,

as specified in the package design approval certificate.

## SCHEDULE 5

Regulations 44 and 45

## DETERMINATION OF TRANSPORT INDEX (TI) OR CRITICALITY SAFETY INDEX (CSI)

1. The Transport Index (TI) for a package, overpack, freight container, or for unpackaged LSA-I or SCO-I, must be the number derived in accordance with the following procedure—

- (a) determine the maximum radiation level in units of mSv/h at a distance of 1 metre from the external surfaces of the package, overpack, freight container, or unpackaged LSA-I and SCO-I. Multiply the value determined by 100. For uranium and thorium ores and their concentrates, the maximum radiation level at any point 1 metre from the external surface of the load may be taken as:
  - (i) 0.4 mSv/h for ores and physical concentrates of uranium and thorium;
  - (ii) 0.3 mSv/h for chemical concentrates of thorium; or
  - (iii) 0.02 mSv/h for chemical concentrates of uranium, other than uranium hexafluoride;
- (b) for tanks, freight containers and unpackaged LSA-I and SCO-I, the value determined in step (a) above must be multiplied by the appropriate factor from Table VI of Schedule 1;
- (c) the figure obtained in steps (a) and (b) above must be rounded up to the first decimal place (e.g., 1.13 becomes 1.2), except that a value of 0.05 or less may be considered as zero.

2. The TI for each overpack, freight container or vehicle must be determined as either the sum of the TIs of all the packages contained, or by direct measurement of radiation level, except in the case of non-rigid overpacks for which the transport index must be determined only as the sum of the TIs of all of the packages.

3. The Criticality Safety Index (CSI) for packages containing fissile material must be obtained by dividing the number 50 by the value of N derived using the procedures specified in paragraph 8 of Part XIV of Schedule 8 (i.e.,  $CSI = 50/N$ ). The value of the CSI may be zero, provided that an unlimited number of packages is subcritical (i.e., N is effectively equal to infinity).

4. The CSI for each consignment must be determined as the sum of the CSIs of all of the packages contained in that consignment.

## SCHEDULE 6

Regulations 11(5),41(2)(c) and 48

## ADDITIONAL RESPONSIBILITIES OF CONSIGNORS

**Marking**

1. Each package must be legibly and durably marked on the outside of the packaging with an identification of either the consignor or consignee, or both.

2. For each package, other than excepted packages, the United Nations number (see column 1 of Table VIII in Schedule 1), preceded by the letters “UN”, and the proper shipping name (see column 2 of Table VIII in Schedule 1) must be legibly and durably marked on the outside of the packaging. In the case of excepted packages, only the United Nations number, preceded by the letters “UN”, is required.

3. Each package of gross mass exceeding 50 kg must have its permissible gross mass legibly and durably marked on the outside of the packaging.

4. Each package which conforms to—

- (a) an Industrial package Type 1, an Industrial package Type 2 or an Industrial package Type 3 design must be legibly and durably marked on the outside of the packaging with “TYPE IP-1”, “TYPE IP-2” or “TYPE IP-3” as appropriate;
  - (b) a Type A package design must be legibly and durably marked on the outside of the packaging with “TYPE A”; or
  - (c) an Industrial package Type 2, an Industrial package Type 3 or a Type A package design must be legibly and durably marked on the outside of the packaging with the international vehicle registration identification code (VRI Code) of the country of origin of design and the name of the manufacturers, or other identification of the packaging specified by the competent authority of the country of origin of design.
5. Each package which conforms to a design approved under regulations 11, 12 or 55 to 58 must be legibly and durably marked on the outside of the packaging with—
- (a) The identification mark allocated to that design by the competent authority;
  - (b) A serial number to uniquely identify each packaging which conforms to that design;
  - (c) In the case of a Type B(U) or Type B(M) package design, with “TYPE B(U)” or “TYPE B(M)”;
  - (d) In the case of a Type C package design, with “TYPE C”.
6. Each package which conforms to a Type B(U), Type B(M) or Type C package design must have the outside of the outermost receptacle which is resistant to the effects of fire and water plainly marked by embossing, stamping or other means resistant to the effects of fire and water with the trefoil symbol shown in Fig. 1 of Schedule 14.
7. Where LSA-I or SCO-I material is contained in receptacles or wrapping materials and is transported under exclusive use as permitted by regulation 43(3), the outer surface of these receptacles or wrapping materials may bear the marking “RADIOACTIVE LSA-I” or “RADIOACTIVE SCO-I”, as appropriate.

### **Labelling**

8. Each package, overpack and freight container must bear the labels which conform to the models in Fig 2, Fig 3 or, Fig 4 of Schedule 14 except as allowed under the alternative provisions of paragraph 13 for large freight containers and tanks, according to the appropriate category. In addition, each package, overpack and freight container containing fissile material, other than fissile material excepted under the provisions of paragraph 3 of Part XIV of Schedule 8, must bear labels which conform to the model in Fig 5 of Schedule 14. Any labels which do not relate to the contents must be removed or covered. For radioactive material having other dangerous properties see regulation 36(1).
9. The labels conforming to the models in Fig 2, Fig. 3 and Fig. 4 of Schedule 14 must be affixed to two opposite sides of the outside of a package or overpack or on the outside of all four sides of a freight container or tank. The labels conforming to the model in Fig. 5 of Schedule 14, where applicable, must be affixed adjacent to the labels conforming to the models in Fig. 2, Fig. 3 and Fig. 4 of Schedule 14. The labels must not cover the markings specified in paragraphs 1-6.

### **Labelling for radioactive contents**

10. Each label conforming to the models in Fig. 2, Fig.3 and Fig. 4 of Schedule 14 must be completed with the following information—
- (a) Contents—
    - (i) Except for LSA-I material, the name(s) of the radionuclide(s) as taken from Table I of Schedule 1, using the symbols prescribed therein. For mixtures of radionuclides,

*Status: This is the original version (as it was originally made).*

the most restrictive nuclides must be listed to the extent the space on the line permits. The group of LSA or SCO must be shown following the name(s) of the radionuclide(s). The terms “LSA-II”, “LSA-III”, “SCO-I” and “SCO-II” must be used for this purpose.

- (ii) For LSA-I material, the term “LSA-I” is all that is necessary; the name of the radionuclide is not necessary.
- (b) Activity: The maximum activity of the radioactive contents during transport expressed in units of becquerels (Bq) with the appropriate SI prefix. For fissile material, the mass of fissile material in units of grams (g), or multiples thereof, may be used in place of activity.
- (c) For overpacks and freight containers, the “contents” and “activity” entries on the label must bear the information required in sub-paragraphs (a) and (b) respectively, totalled together for the entire contents of the overpack or freight container except that on labels for overpacks or freight containers containing mixed loads of packages containing different radionuclides, such entries may read “See Transport Documents”.
- (d) Transport index: The value calculated in accordance with regulation 44. (No transport index entry is required for category I-WHITE.)

### **Labelling for criticality safety**

**11.** Each label conforming to the model in Fig.5 of Schedule 14 must be completed with the criticality safety index (CSI) as stated in the certificate of approval for special arrangement or the certificate of approval for the package design issued by the competent authority.

**12.** For overpacks and freight containers, the criticality safety index (CSI) on the label must bear the information required in paragraph 11 totalled together for the fissile contents of the overpack or freight container.

### **Placarding**

**13.** Large freight containers carrying packages other than excepted packages, and tanks must bear four placards which conform to the model given in Fig. 6 of Schedule 14. The placards must be affixed in a vertical orientation to each side wall and each end wall of the large freight container or tank. Any placards which do not relate to the contents must be removed. Instead of using both labels and placards, it is permitted as an alternative to use enlarged labels only, as shown in Fig. 2, Fig. 3, Fig. 4, and Fig. 5 of Schedule 14 where appropriate, with dimensions of the minimum size shown in Fig. 6 of Schedule 14.

**14.** Where the consignment in the freight container or tank is unpackaged LSA-I or SCO-I or where an exclusive use consignment in a freight container is packaged radioactive material with a single United Nations number, the appropriate United Nations number for the consignment (as shown in column 1 of Table VIII in Schedule 1) must also be displayed, in black digits not less than 65 mm high, either—

- (a) in the lower half of the placard shown in Fig. 6 of Schedule 14, (and may be preceded by the letters “UN”) and against the white background; or
- (b) on the placard specified in paragraph 30.

When the alternative given in (b) above is used, the subsidiary placard must be affixed immediately adjacent to the main placard, on all four sides of the freight container or tank.

**15.** Vehicles carrying packages, overpacks or freight containers labelled with any of the labels shown in Fig. 2, Fig. 3, Fig. 4 or Fig. 5 of Schedule 14, or carrying consignments under exclusive use, must display the placard shown in Fig. 6 of Schedule 14 on each of the two external lateral walls and the external rear wall.

**In the case of a vehicle without sides the placards may be affixed directly on the cargo-carrying unit provided that they are readily visible; in the case of physically large tanks or freight containers, the placards on the tanks or freight containers will suffice. In the case of vehicles which have insufficient area to allow the fixing of larger placards, the dimensions of the placard as described in Fig. 6 of Schedule 14 may be reduced to 100 mm. Any placards which do not relate to the contents must be removed.**

16. Where the consignment in or on the vehicle is unpackaged LSA-I material or SCO-I or where an exclusive use consignment is packaged radioactive material with a single United Nations number, the appropriate United Nations number (see Table VIII) must also be displayed, in black digits not less than 65 mm high, either—

- (a) in the lower half of the placard shown in Fig. 6 of Schedule 14, (and may be preceded by the letters “UN”) and against the white background; or
- (b) on the placard specified in paragraph 30.

When the alternative given in (b) above is used, the subsidiary placard must be affixed immediately adjacent to the main placard, either on the two external lateral walls in the case of a rail vehicle or the two external lateral walls and the external rear wall in the case of a road vehicle.

#### **Particulars of consignment**

17. The consignor must include in the transport documents with each consignment the following information, as applicable—

- (a) a heading or a reference to these regulations;
- (b) the name of the consignor and an address and telephone number by which he can be contacted in the event of an accident occurring during the transport of a consignment;
- (c) the name and address of the consignee;
- (d) the proper shipping name, as specified in column 2 of Table VIII in Schedule 1;
- (e) the United Nations Class Number “7”;
- (f) the United Nations Number assigned to the material as specified in column 1 of Table VIII in Schedule 1, the number is to be prefixed with the letters “UN”;
- (g) the name or symbol of each radionuclide or, for mixtures of radionuclides, an appropriate general description or a list of the most restrictive nuclides;
- (h) a description of the physical and chemical form of the material, or a notation that the material is special form radioactive material or low dispersible radioactive material. A generic chemical description is acceptable for chemical form;
- (i) the maximum activity of the radioactive contents during transport expressed in units of becquerels with an appropriate SI prefix. For fissile material, the mass of fissile material in grams (g), or appropriate multiples thereof, may be used in place of activity;
- (j) the category of the package, i.e., I-WHITE, II-YELLOW, or III-YELLOW;
- (k) the Transport Index (TI) (categories II-YELLOW and III-YELLOW only);
- (l) for consignments including fissile material other than consignments where all of the packages meet the requirements of paragraph 3 of Part XIV of Schedule 8, the criticality safety index (CSI);
- (m) the identification mark for each competent authority approval certificate (special form radioactive material, low dispersible radioactive material, special arrangement, package design, or shipment) applicable to the consignment;
- (n) for consignments of packages in an overpack or freight container, a detailed statement of the contents of each package within the overpack or freight container and, where

*Status: This is the original version (as it was originally made).*

appropriate, of each overpack or freight container in the consignment. If packages are to be removed from the overpack or freight container at a point of intermediate unloading, appropriate transport documentation must be made available;

- (o) where a consignment is required to be shipped under exclusive use, the statement “EXCLUSIVE USE SHIPMENT”; and
- (p) for LSA-II, LSA-III, SCO-I and SCO-II the total activity of the consignment as a multiple of A<sub>2</sub>.

### **Declaration**

18. The consignor must include in the transport documents a declaration in the following terms or in terms having an equivalent meaning:

“I hereby declare that the contents of this consignment are fully and accurately described above by the proper shipping name and are classified, packed, marked and labelled, and are in all respects in proper condition for transport by (insert mode(s) of transport involved) according to the applicable international and national governmental regulations.”

19. If the intent of the declaration is already a condition of transport within a particular international convention, the consignor need not provide such a declaration for that part of the transport covered by the convention.

20. The declaration must be signed and dated by the consignor. A facsimile signature is authorised.

21. The declaration must be made on the same transport document that contains the particulars of consignment listed in paragraph 17.

### **Removal or covering of labels**

22. When an empty packaging is transported as an excepted package in accordance with regulation 42, the previously displayed labels must not be visible.

### **Information for carriers**

23. The consignor must provide in the transport documents a statement regarding actions, if any, that are required to be taken by the carrier. The statement must be in the languages deemed necessary by the carrier or the authorities concerned, and must include at least the following points—

- (a) supplementary requirements for loading, stowage, carriage, handling and unloading of the package, overpack or freight container including any special stowage provisions for the safe dissipation of heat (see paragraph 5 of Schedule 7), or a statement that no such requirements are necessary;
- (b) restrictions on the mode of transport or conveyance and any necessary routing instructions;
- (c) emergency arrangements appropriate to the consignment.

24. The applicable competent authority certificates need not necessarily accompany the consignment. The consignor must make them available to the carrier before loading and unloading.

### **Notification of competent authorities**

25. Before the first shipment of any package requiring competent authority approval, the consignor must ensure that copies of each applicable competent authority certificate applying to that package design have been submitted to the competent authority of each country through or into which the consignment is to be transported. The consignor is not required to await an



acknowledgement from the competent authority, nor is the competent authority required to make such acknowledgement of receipt of the certificate.

26. For each shipment listed in (a), (b), (c) or (d) below, the consignor must notify the competent authority of each country through or into which the consignment is to be transported. This notification must be in the hands of each competent authority prior to the commencement of the shipment, and preferably at least 7 days in advance.

- (a) Type C packages containing radioactive material with an activity greater than 3000 A<sub>1</sub> or 3000 A<sub>2</sub>, as appropriate, or 1000 TBq, whichever is the lower;
- (b) Type B(U) packages containing radioactive material with an activity greater than 3000 A<sub>1</sub> or 3000 A<sub>2</sub>, as appropriate, or 1000 TBq, whichever is the lower;
- (c) Type B(M) packages;
- (d) Shipment under special arrangement.

27. The consignment notification must include—

- (a) sufficient information to enable the identification of the package or packages including all applicable certificate numbers and identification marks;
- (b) information on the date of shipment, the expected date of arrival and proposed routeing;
- (c) the names of the radioactive materials or nuclides;
- (d) descriptions of the physical and chemical forms of the radioactive material, or whether it is special form radioactive material or low dispersible radioactive material; and
- (e) the maximum activity of the radioactive contents during transport expressed in units of becquerels (Bq) with an appropriate SI prefix. For fissile material, the mass of fissile material in units of grams (g), or multiples thereof, may be used in place of activity.

28. The consignor is not required to send a separate notification if the required information has been included in the application for shipment approval; see part V of Schedule 10.

#### **Possession of certificates and instructions**

29. The consignor must have in his or her possession a copy of each certificate of approval required under Part XI of these Regulations and a copy of the instructions with regard to the proper closing of the package and other preparations for shipment before making any shipment under the terms of the certificates.

#### **“ADR” orange plate**

30. Vehicles must be placarded according to the applicable provisions of ADR paragraph 5.3.2.

## SCHEDULE 7

Regulations 20(1) and 49

### RESPONSIBILITIES OF CARRIERS

#### **Segregation of packages etc during transport and storage in transit**

1. Packages, overpacks and freight containers containing radioactive material must be segregated during transport and during storage in transit—

- (a) from places occupied by persons and from undeveloped photographic film, for radiation exposure control purposes, in accordance with regulation 25; and

*Status: This is the original version (as it was originally made).*

(b) from other dangerous goods in accordance with regulation 36.

2. Category II-YELLOW or III-YELLOW packages or overpacks must not be carried in compartments occupied by passengers, except those exclusively reserved for couriers specially authorised to accompany such packages or overpacks.

3. No persons other than the driver and assistants must be permitted in vehicles carrying packages, overpacks or freight containers bearing category II-YELLOW or III-YELLOW labels.

#### **Stowage during transport and storage in transit**

4. Consignments must be securely stowed.

5. Provided that its average surface heat flux does not exceed  $15 \text{ W/m}^2$  and that the immediately surrounding cargo is not in sacks or bags, a package or overpack may be carried or stored among packaged general cargo without any special stowage provisions except as may be specifically required by the competent authority in an applicable approval certificate.

6. Loading of freight containers and accumulation of packages, overpacks and freight containers must be controlled as follows—

(a) except under the condition of exclusive use, the total number of packages, overpacks and freight containers aboard a single vehicle must be so limited that the total sum of the transport indexes aboard the vehicle does not exceed 50. For consignments of LSA-I material there shall be no limit on the sum of the transport indexes;

(b) where a consignment is transported under exclusive use, there shall be no limit on the sum of the transport indexes aboard a single vehicle;

c. the radiation level under routine conditions of transport must not exceed  $2 \text{ mSv/h}$  at any point on, and  $0.1 \text{ mSv/h}$  at 2 m from, the external surface of the vehicle;

(d) the total sum of the criticality safety indexes (CSI) in a freight container not under exclusive use and aboard a vehicle not under exclusive use must not exceed 50. For large containers and vehicles under exclusive use, the CSI must not exceed 100.

7. Any package or overpack having either a transport index greater than 10, or any consignment having a criticality safety index greater than 50, must be transported only under exclusive use.

8. For consignments under exclusive use, the radiation level must not exceed—

(a)  $10 \text{ mSv/h}$  at any point on the external surface of any package or overpack, and may only exceed  $2 \text{ mSv/h}$  provided that—

(i) the vehicle is equipped with an enclosure which, during routine conditions of transport, prevents the access of unauthorized persons to the interior of the enclosure, and

(ii) provisions are made to secure the package or overpack so that its position within the vehicle remains fixed during routine conditions of transport, and

(iii) there is no loading or unloading during the shipment;

b.  $2 \text{ mSv/h}$  at any point on the outer surfaces of the vehicle, including the upper and lower surfaces, or, in the case of an open vehicle, at any point on the vertical planes projected from the outer edges of the vehicle, on the upper surface of the load, and on the lower external surface of the vehicle; and

c.  $0.1 \text{ mSv/h}$  at any point 2 m from the vertical planes represented by the outer lateral surfaces of the vehicle, or, if the load is transported in an open vehicle, at any point 2 m from the vertical planes projected from the outer edges of the vehicle.

### **Segregation of packages containing fissile material during transport and storage in transit**

**9.** The number of packages, overpacks and freight containers containing fissile material stored in transit in any one storage area must be so limited that the total sum of the criticality safety indexes in any group of such packages, overpacks or freight containers does not exceed 50. Groups of such packages, overpacks and freight containers must be stored so as to maintain a spacing of at least 6 m from other groups of such packages, overpacks or freight containers.

**10.** Where the total sum of the criticality safety indexes on board a vehicle or in a freight container exceeds 50, storage must be such as to maintain a spacing of at least 6 m from other groups of packages, overpacks or freight containers containing fissile material or other conveyances carrying radioactive material.

### **Undeliverable Consignments**

**11.** Where a consignment is undeliverable, the consignment must be placed in a safe location and the Secretary of State must be informed as soon as possible and a request made for instructions on further action.

**12.** Vehicles must be equipped in accordance with the provisions of ADR paragraph 8.1.4

## **SCHEDULE 8**

Regulations 31(2)(c), 32(2), 41(2)(b) and  
(c) and others 50, 55(1)(b), 58(1) and  
60(1)(a)

### **REQUIREMENTS FOR RADIOACTIVE MATERIALS AND FOR PACKAGINGS AND PACKAGES**

#### **PART I**

##### **REQUIREMENTS FOR LSA-III MATERIAL**

LSA-III material must be a solid of such a nature that if the entire contents of a package were subjected to the test specified in paragraph Part I of Schedule 9 the activity in the water would not exceed 0.1 A<sub>2</sub>.

#### **PART II**

##### **REQUIREMENTS FOR SPECIAL FORM RADIOACTIVE MATERIAL**

- 1.** Special form radioactive material must have at least one dimension not less than 5 mm.
- 2.** Special form radioactive material must be of such a nature or must be so designed that if it is subjected to the tests specified in Part II of Schedule 9, it meets the following requirements—
  - (a) it would not break or shatter under the impact, percussion and bending tests in paragraphs 4, 5, 6 and 8(a) of that Part of that Schedule as applicable;
  - (b) it would not melt or disperse in the heat test in paragraphs 7 and 8(b) of that Part of that Schedule as applicable; and
  - (c) the activity in the water from the leaching tests specified in paragraphs 9 and 10 of that Part of that Schedule would not exceed 2 kBq; or alternatively for sealed sources, the leakage

*Status: This is the original version (as it was originally made).*

rate for the volumetric leakage assessment test specified in the ISO leak test document would not exceed the applicable acceptance threshold acceptable to the Secretary of State.

3. When a sealed capsule constitutes part of the special form radioactive material, the capsule must be so manufactured that it can be opened only by destroying it.

## PART III

### REQUIREMENTS FOR LOW DISPERSIBLE RADIOACTIVE MATERIAL

Low dispersible radioactive material must be such that the total amount of this radioactive material in a package must meet the following requirements—

- (a) the radiation level at 3 m from the unshielded radioactive material does not exceed 10 mSv/h;
- (b) if subjected to the tests specified in paragraphs 25 and 26 of Part IV of Schedule 9, the airborne release in gaseous and particulate forms of up to 100  $\mu\text{m}$  aerodynamic equivalent diameter would not exceed 100  $A_2$ . A separate specimen may be used for each test; and
- (c) if subjected to the test specified in Part I of Schedule 9 the activity in the water would not exceed 100  $A_2$ . In the application of this test, the damaging effects of the tests specified in (b) above must be taken into account.

## PART IV

### GENERAL REQUIREMENTS FOR PACKAGINGS AND PACKAGES

1. A package must be so designed in relation to its mass, volume and shape that it can easily and safely be handled and transported and so that it can be properly secured in or on the vehicle during transport.

2. The design of a package must be such that any lifting attachments on it will not fail when used in the intended manner and such that, if failure of the attachments should occur, the ability of the package to meet other requirements of these Regulations would not be impaired, taking into account appropriate safety factors to cover snatch lifting.

3. Any attachment or other feature on the outer surface of a package which could be used to lift it but is not designed to support its mass in accordance with paragraph 2 above must be removed or otherwise rendered incapable of being used during transport.

4. As far as reasonably practicable, packaging must be so designed and finished that the external surfaces are free from protruding features and can easily be decontaminated.

5. As far as reasonably practicable, the outer layer of a package must be so designed as to prevent the collection and retention of water.

6. No feature, not forming an integral part of a package, is to be added to the package at the time of transport if it will reduce the safety of the package.

7. A package must be capable of withstanding the effects of any acceleration, vibration or vibration resonance which may arise under routine conditions of transport without any deterioration in the effectiveness of the closing devices on the various receptacles or in the integrity of the package as a whole, and in particular nuts, bolts, and other securing devices must be so designed as to prevent them from becoming loose or being released unintentionally, even after repeated use.

**8.** The materials of the packaging and any components or structures thereof must be physically and chemically compatible with each other and with the radioactive contents, taking into account their behaviour under irradiation.

**9.** All valves through which radioactive contents could otherwise escape must be protected against unauthorised operation.

**10.** The design of the package must take into account ambient temperatures and pressures that are likely to be encountered in routine conditions of transport.

**11.** For radioactive material having other dangerous properties, the package design must take into account those properties; see regulations 6(2) and 36.

## PART V

### REQUIREMENTS FOR EXCEPTED PACKAGES

The package must comply with Part IV of this Schedule.

## PART VI

### REQUIREMENTS FOR AN INDUSTRIAL PACKAGE TYPE 1 (IP-1)

An industrial package Type 1 (IP-1) must be designed to meet the requirements of Part IV of this Schedule and the smallest overall external dimension must not be less than 10 cm.

## PART VII

### REQUIREMENTS FOR AN INDUSTRIAL PACKAGE TYPE 2 (IP-2)

**1.** An industrial package Type 2 (IP-2) must be designed to meet the requirements of Part VI of this Schedule and, when subjected to the tests specified in paragraphs 10 and 11 of Part IV of Schedule 9, it must prevent—

- (a) the loss or dispersal of the radioactive contents; and
- (b) the loss of shielding integrity which would result in more than a 20% increase in the radiation level at any external surface of the package; or alternatively paragraph 2.

**2.** An industrial package Type 2 (IP-2) must be designed—

- (a) to meet the requirements of Part VI of this Schedule and
- (b) to conform to the standards prescribed in chapter 6.1 of ADR, or other requirements at least equivalent to those standards, and
- (c) when subjected to the tests required for UN packing group I or II in chapter 6.1 of ADR, must prevent:
  - (i) the loss or dispersal of the radioactive contents; and
  - (ii) the loss of shielding integrity which would result in more than a 20% increase in the radiation level at any external surface of the package; or alternatively meet the requirements of paragraph 3, 4, 5 or 6.

**3.** A tank container may be used as an industrial package Type 2 (IP-2) provided that it is designed—

- (a) to meet the requirements of Part VI of this Schedule, and

*Status: This is the original version (as it was originally made).*

- (b) to conform to the standards prescribed in the Chapter 6.8 of ADR, or other requirements at least equivalent to those standards, and is capable of withstanding a test pressure of 265kPa, and
  - (c) so that any additional shielding which is provided is capable of withstanding the static and dynamic stresses resulting from handling and routine conditions of transport and of preventing a loss of shielding integrity which would result in more than a 20% increase in the radiation level at any external surface of the tank container.
4. A tank may be used as an industrial package Type 2 (IP-2) provided that it conforms to standards at least equivalent to those required in the case of tank containers by paragraph 3, but substitute the ADR reference in paragraph 3(b) for “Chapter 6.7 of ADR”, and it is limited to transporting LSA-I or LSA-II liquids or gases as prescribed in Table IV of Schedule 1.
5. A freight container may be used as an industrial package Type 2 (IP-2) provided that—
- (a) it is designed to meet the requirements of Part VI of this Schedule and
  - (b) it is designed to conform to the requirements prescribed in the ISO freight containers document, and
  - (c) the radioactive contents are restricted to solid materials, and
  - (d) if it were subjected to the tests prescribed in ISO freight containers document and the accelerations occurring during routine conditions of transport, it would prevent—
    - (i) loss or dispersal of the radioactive contents; and
    - (ii) loss of shielding integrity which would result in more than a 20% increase in the radiation level at any external surface of the freight container.
6. An intermediate bulk container may be used as an industrial package Type 2 (IP-2) provided that—
- (a) it is designed to meet the requirements of Part VI of this Schedule and
  - (b) it is metal, and
  - (c) it is designed to conform to the requirements prescribed Chapter 6.1 of ADR, and if it were subjected to the tests for UN Packing Group I or II prescribed in that document, but with the drop test conducted in the most damaging orientation, it would prevent—
    - (i) loss or dispersal of the radioactive contents; and
    - (ii) loss of shielding integrity which would result in more than a 20% increase in the radiation level at any external surface of the intermediate bulk container.

## PART VIII

### REQUIREMENTS FOR AN INDUSTRIAL PACKAGE TYPE 3 (IP-3)

1. An industrial package Type 3 (IP-3) must be designed to meet the requirements of Part VI of this Schedule and, in addition the requirements of paragraphs 2 to 15 of Part X of this Schedule; or alternatively may meet the requirements of paragraphs 2,3,4 or 5.
2. A tank container may be used as an industrial package Type 3 (IP-3) provided that it is designed—
- (a) to meet the requirements of Part VI of this Schedule, and
  - (b) to conform to the standards prescribed in the Chapter 6.8 of ADR, or other requirements at least equivalent to those standards, and is capable of withstanding a test pressure of 265 kPa, and

- (c) so that any additional shielding which is provided must be capable of withstanding the static and dynamic stresses resulting from handling and routine conditions of transport and of preventing a loss of shielding integrity which would result in more than a 20% increase in the radiation level at any external surface of the tank container.
3. A tank may be used as an industrial package Type 3 (IP-3) provided that it conforms to standards at least equivalent to those required in the case of tank containers by paragraph 2, but substitute “to conform to the standards prescribed in chapter 6.7 of ADR” for paragraph 2(b), and it must be limited to transporting LSA-I or LSA-II liquids or gases as prescribed in Table IV of Schedule 1.
4. A freight container may be used as an industrial package Type 3 (IP-3) provided that—
- (a) it is designed to meet the requirements of Part VI of this Schedule and
  - (b) it is designed to conform to the requirements prescribed in the ISO freight containers document, and
  - (c) the radioactive contents are restricted to solid materials, and
  - (d) if it were subjected to the tests prescribed in ISO freight containers document and the accelerations occurring during routine conditions of transport, it would prevent:
    - (i) loss or dispersal of the radioactive contents; and
    - (ii) loss of shielding integrity which would result in more than a 20% increase in the radiation level at any external surface of the freight container.
5. An intermediate bulk container may be used as an industrial package Type 3 (IP-3) provided that—
- (a) it must be designed to meet the requirements of Part VI of this Schedule and
  - (b) it is metal, and
  - (c) it is designed to conform to the requirements prescribed Chapter 6.1 of the Dangerous Goods Recommendations, and if it were subjected to the tests for UN Packing Group I or II prescribed in that document, but with the drop test conducted in the most damaging orientation, it would prevent—
    - (i) loss or dispersal of the radioactive contents; and
    - (ii) loss of shielding integrity which would result in more than a 20% increase in the radiation level at any external surface of the intermediate bulk container.

## PART IX

### REQUIREMENTS FOR PACKAGES CONTAINING URANIUM HEXAFLUORIDE

1. The package must also meet the requirements prescribed elsewhere in these Regulations which pertain to the radioactive and fissile properties of the material. Except as allowed in paragraph 4, uranium hexafluoride in quantities of 0.1 kg or more must also be packaged and transported in accordance with the provisions of the International Organisation for Standardisation document ISO 7195, “Packaging of uranium hexafluoride (UF<sub>6</sub>) for transport”, and the requirements of paragraphs 2 and 3.
2. Each package designed to contain 0.1 kg or more of uranium hexafluoride must be designed so that it would meet the following requirements—

*Status: This is the original version (as it was originally made).*

- (a) withstand without leakage and without unacceptable stress, as specified in the International Organization for Standardization document ISO 7195 , the structural test as specified in paragraph 6 of Part IV of Schedule 9;
  - (b) withstand without loss or dispersal of the uranium hexafluoride the test specified in paragraph 10 of Part IV of Schedule 9; and
  - (c) withstand without rupture of the containment system the test specified in paragraph 16 of Part IV of Schedule 9.
3. Packages designed to contain 0.1 kg or more of uranium hexafluoride must not be provided with pressure relief devices.
4. Subject to the approval of the competent authority, packages designed to contain 0.1 kg or more of uranium hexafluoride may be transported if—
- (a) the packages are designed to requirements other than those given in ISO 7195 and paragraphs 2-3 but, notwithstanding, the requirements of paragraphs 2-3 are met as far as practicable;
  - (b) the packages are designed to withstand without leakage and without unacceptable stress a test pressure less than 2.76 MPa as specified in paragraph 6 of Part IV of Schedule 9; or
  - (c) for packages designed to contain 9000 kg or more of uranium hexafluoride, the packages do not meet the requirement of paragraph 2(c).

## PART X

### REQUIREMENTS FOR TYPE A PACKAGES

1. A Type A package must meet the requirements of Part IV of this Schedule.
2. The smallest overall external dimension of the package must not be less than 10 cm.
3. The outside of the package must incorporate a feature such as a seal, which is not readily breakable and which, while intact, will be evidence that it has not been opened.
4. Any tie-down attachments on the package must be so designed that, under both normal and accident conditions of transport, the forces in those attachments do not impair the ability of the package to meet the requirements of these Regulations.
5. The design of the package must take into account temperatures ranging from  $-40^{\circ}\text{C}$  to  $70^{\circ}\text{C}$  for the components of the packaging, giving attention to freezing temperatures for liquid contents and to the potential degradation of packaging materials within the given temperature range.
6. The design and manufacturing techniques must be in accordance with national or international standards, or other requirements, acceptable to the Secretary of State
7. The design must include a containment system securely closed by a positive fastening device which cannot be opened unintentionally or by a pressure which may arise within the package.
8. Special form radioactive material may be considered as a component of the containment system.
9. If the containment system forms a separate unit of the package, it must be capable of being securely closed by a positive fastening device which is independent of any other part of the packaging.
10. The design of any component of the containment system must take into account, where applicable, the radiolytic decomposition of liquids and other vulnerable materials and the generation of gas by chemical reaction and radiolysis.



**11.** The containment system must retain its radioactive contents under a reduction of ambient pressure to 60 kPa.

**12.** All valves, other than pressure relief valves, must be provided with an enclosure to retain any leakage from the valve.

**13.** A radiation shield which encloses a component of the package specified as a part of the containment system must be so designed as to prevent the unintentional release of that component from the shield. Where the radiation shield and such component within it form a separate unit, the radiation shield must be capable of being securely closed by a positive fastening device which is independent of any other packaging structure.

**14.** A package must be so designed that, if it were subjected to the tests specified in paragraphs 7 to 12 of Part IV of Schedule 9, it would prevent—

- (a) loss or dispersal of the radioactive contents; and
- (b) loss of shielding integrity which would result in more than a 20% increase in the radiation level at any external surface of the package.

**15.** The design of a package intended for liquid radioactive material must make provision for ullage to accommodate variations in the temperature of the contents, dynamic effects and filling dynamics.

**16.** A Type A package designed to contain liquids must, in addition—

- (a) be adequate to meet the conditions specified in paragraph 14 if the package is subjected to the tests specified in paragraph 13 of Part IV of Schedule 9; and
- (b) either—
  - (i) be provided with sufficient absorbent material to absorb twice the volume of the liquid contents (such absorbent material must be suitably positioned so as to contact the liquid in the event of leakage); or
  - (ii) be provided with a containment system composed of primary inner and secondary outer containment components designed to ensure retention of the liquid contents, within the secondary outer containment components, even if the primary inner components leak.

**17.** A package designed for gases must prevent loss or dispersal of the radioactive contents if the package were subjected to the tests specified in paragraph 13 of Part IV of Schedule 9. A package designed for tritium in gaseous form or for noble gases with contents not exceeding  $A_2$  is excepted from this requirement.

## PART XI

### REQUIREMENTS FOR TYPE B(U) PACKAGES

**1.** A Type B(U) package must be designed to meet the requirements of Part IV, and of paragraphs 2 to 13, and 15, of Part X, and of paragraph 14 of Part X except as specified in paragraph 7(a) below.

**2.** A package must be so designed that, under the ambient conditions specified in paragraphs 4 and 5, heat generated within the package by the radioactive contents must not, under normal conditions of transport, as demonstrated by the tests in paragraphs 7 – 12 of Part IV of Schedule 9, adversely affect the package in such a way that it would fail to meet the applicable requirements for containment and shielding if left unattended for a period of one week. Particular attention is to be paid to the effects of heat which may—

*Status: This is the original version (as it was originally made).*

- (a) alter the arrangement, the geometrical form or the physical state of the radioactive contents or, if the radioactive material is enclosed in a can or receptacle (for example, clad fuel elements), cause the can, receptacle or radioactive material to deform or melt; or
  - (b) lessen the efficiency of the packaging through differential thermal expansion or cracking or melting of the radiation shielding material; or
  - (c) in combination with moisture, accelerate corrosion.
3. A package must be so designed that, under the ambient condition specified in paragraph 4, the temperature of its accessible surfaces must not exceed 50°C, unless the package is transported under exclusive use.
4. The ambient temperature must be assumed to be 38°C.
5. The solar insolation conditions must be assumed to be as specified in Table IX of Schedule 1.
6. A package which includes thermal protection for the purpose of satisfying the requirements of the thermal test specified in paragraph 16 of Part IV of Schedule 9 must be so designed that such protection will remain effective if the package is subjected to the tests specified in paragraphs 7 – 12 and 15(a) and (b) or 15(b) and (c) of Part IV of Schedule 9, as appropriate. Any such protection on the exterior of the package must not be rendered ineffective by ripping, cutting, skidding, abrasion, or rough handling.
7. A package must be so designed that, if it were subjected to—
- (a) the tests specified in paragraphs 7 – 12 of Part IV of Schedule 9, it would restrict the loss of radioactive contents to not more than  $10^{-6}A_2$  per hour; and
  - (b) the tests specified in paragraphs 14, 15(b), 16 and 17 of that Part of that Schedule and the test in paragraph—
    - (i) 15(c) of that Part of that Schedule, when the package has a mass not greater than 500 kg, an overall density not greater than  $1000 \text{ kg/m}^3$  based on the external dimensions, and radioactive contents greater than  $1000 A_2$  not as special form radioactive material, or
    - (ii) 15(a) of that Part of that Schedule for all other packages,
 it would retain sufficient shielding to ensure that the radiation level at 1 metre from the surface of the package would not exceed 10 mSv/h with the maximum radioactive contents which the package is designed to contain and it would restrict the accumulated loss of radioactive contents in a period of one week to not more than  $10 A_2$  for krypton-85 and not more than  $A_2$  for all other radionuclides. Where mixtures of different radionuclides are present, the provisions of parts 4 and 5 of regulation 29 must apply except that for krypton-85 an effective  $A_2(i)$  value equal to  $10 A_2$  may be used. For the purposes of sub-paragraph (a) above, the evaluation must take into account the requirements of regulation 37(2)(a).
8. A package for radioactive contents with activity greater than  $105 A_2$  must be so designed that if it were subjected to the water immersion test specified in paragraph 18 of Part IV of Schedule 9, there would be no rupture of the containment system.
9. Compliance with the permitted activity release limits must not depend either upon filters or upon a mechanical cooling system.
10. A package must not include a pressure relief system from the containment system which would allow the release of radioactive material to the environment under the conditions of the tests specified in paragraphs 7 – 12 and 14 – 17 of Part IV of Schedule 9.

11. A package must be so designed that if it were at the maximum normal operating pressure and it were subjected to the tests specified in paragraphs 7 – 12 and 14 – 17 of Part IV of Schedule 9, the level of strains in the containment system would not attain values which would adversely affect the package in such a way that it would fail to meet the applicable requirements.

12. A package must not have a maximum normal operating pressure in excess of a gauge pressure of 700 kPa.

13. The maximum temperature of any surface readily accessible during transport of a package must not exceed 85°C in the absence of insolation under the ambient condition specified in paragraph 4. Account may be taken of barriers or screens intended to give protection to persons without the need for the barriers or screens being subject to any test.

14. A package containing low dispersible radioactive material must be so designed that any features added to the low dispersible radioactive material that are not part of it, or any internal components of the packaging must not adversely affect the performance of the low dispersible radioactive material.

15. A package must be designed for an ambient temperature range from –40°C to +38°C.

## PART XII

### REQUIREMENTS FOR TYPE B(M) PACKAGES

1. A Type B(M) package must meet the requirements of Part XI, except that for packages to be transported within the United Kingdom or between the United Kingdom and another State, conditions other than those given in paragraph 5 of Part X, paragraph 4, 5 and 8-15 of Part XI may be assumed with the approval of the Secretary of State and the competent authority of any State through or to which it is to be transported. As far as reasonably practicable the requirements of paragraphs 8-15 of Part XI must be met.

2. Intermittent venting of Type B(M) packages may be permitted during transport, provided that the operational controls for venting are acceptable to the Secretary of State.

## PART XIII

### REQUIREMENTS FOR TYPE C PACKAGES

1. A Type C package must be designed to meet the requirements of Part IV, and of paragraphs 2 to 13, and 15, of Part X, of paragraph 14 of Part X except as specified in paragraph 3(a) below, of paragraphs 2-5 and 9-15 of Part XI.

2. A package must be capable of meeting the assessment criteria prescribed for tests in paragraphs 7(b) and 11 of Part XI after burial in an environment defined by a thermal conductivity of 0.33 W/m.K and a temperature of 38°C in the steady state. Initial conditions for the assessment must assume that any thermal insulation of the package remains intact, the package is at the maximum normal operating pressure and the ambient temperature is 38°C.

3. A package must be so designed that, if it were at the maximum normal operating pressure and subjected to—

- (a) the tests specified in paragraphs 7-12 of Part IV of Schedule 9, it would restrict the loss of radioactive contents to not more than  $10^{-6}$  A<sub>2</sub> per hour; and
- (b) the test sequences in paragraph 22 of Part IV of Schedule 9:

*Status: This is the original version (as it was originally made).*

- (c) it would retain sufficient shielding to ensure that the radiation level at 1 metre from the surface of the package would not exceed 10 mSv/h with the maximum radioactive contents which the package is designed to contain and it would restrict the accumulated loss of radioactive contents in a period of one week to not more than 10 A<sub>2</sub> for krypton-85 and not more than A<sub>2</sub> for all other radionuclides.

Where mixtures of different radionuclides are present, the provisions of paragraphs (4) and (5) of regulation 29 must apply except that for krypton-85 an effective A<sub>2</sub>(i) value equal to 10 A<sub>2</sub> may be used. For the purposes of sub-paragraph (a) above, the evaluation must take into account the requirements of regulation 37(2)(a).

4. A package must be so designed that there will be no rupture of the containment system following performance of the enhanced water immersion test specified in paragraph 18 of Part IV of Schedule 9.

## PART XIV

### REQUIREMENTS FOR PACKAGES CONTAINING FISSILE MATERIAL

1. Fissile material must be packaged and shipped in such a manner that subcriticality is maintained under conditions likely to be encountered during normal and accident conditions of transport. The following contingencies must be considered—

- (a) water leaking into or out of packages;
- (b) the loss of efficiency of built-in neutron absorbers or moderators;
- (c) rearrangement of the radioactive contents either within the package or as a result of loss from the package;
- (d) reduction of spaces within or between packages;
- (e) packages becoming immersed in water or buried in snow; and
- (f) temperature changes.

2. A package containing fissile material must meet the requirements of paragraph 2 of Part X and those requirements prescribed elsewhere in these Regulations which pertain to the radioactive properties of the material.

3. Packages are excepted from meeting the requirements of paragraphs 4- 10 where they are transported in a consignment meeting one of the exception criteria (a), (b), (c) or (d)—

- (a) the mass of fissile material in the consignment is controlled such that—

$$\frac{\text{mass of uranium } 235(g)}{X} - \frac{\text{mass of other fissile material (g)}}{Y} < 1$$

where X and Y are the mass limits defined in Table X of Schedule 1, and the mass of beryllium and deuterium is controlled such that it does not exceed 0.1% of the fissile material mass allowed and provided that either—

- (i) for packaged material each package contains individually not more than 15g of fissile material, or
- (ii) for unpackaged material the vehicle contains not more than 15g of fissile material, or
- (iii) the fissile material is a homogeneous hydrogenous solution or mixture where the ratio of fissile nuclides to hydrogen is less than 5% by mass, or
- (iv) there is not more than 5g of fissile material in any 10 litre volume of material.

**b.** each package containing uranium enriched in uranium-235 to a maximum of 1% by mass, and with a total plutonium and uranium-233 content not exceeding 1% of the mass of uranium-235, provided that the fissile material is distributed essentially homogeneously throughout the material; provided also that if uranium-235 is present in metallic, oxide, or carbide forms, it does not form a lattice arrangement.

**c.** each package containing liquid solutions of uranyl nitrate enriched in uranium-235 to a maximum of 2% by mass, with a total plutonium and uranium-233 content not exceeding 0.002% of the mass of uranium-235, and with a minimum nitrogen to uranium atomic ratio (N/U) of 2.

**d.** each package containing individually not more than 1 kg of total plutonium, of which not more than 20% by mass may consist of plutonium-239, plutonium-241, or any combination of those radionuclides.

**4.** A packaging for fissile material must be so designed that, if it were subjected to the tests specified in paragraphs 7 -12 of Part IV of Schedule 9 the construction of the packaging would prevent the entry of a 10 cm cube.

**5.** For the purposes of this Part:

“undamaged”, in relation to a package means the evaluated or demonstrated condition of the package if it had been subjected to the tests specified in paragraphs 7 – 12 of Part IV of Schedule 9;

“damaged”, in relation to a package, means the evaluated or demonstrated condition of the package if it had been subjected to whichever of the following combination of tests is the more limiting—

(a) the tests specified in paragraphs 7 – 12 of Part IV of Schedule 9 followed by the tests specified in paragraphs 15 and 16 of that Part of that Schedule and completed by the tests specified in paragraphs 19 – 21 of that Part of that Schedule (the mechanical test of paragraph 15 of that Part of that Schedule must be the tests specified in paragraphs 15(b)) and the test in paragraph—

(i) 15(c) of that Part of that Schedule, when the package has a mass not greater than 500 kg and an overall density not greater than  $1000 \text{ kg/m}^3$  based on the external dimensions, or

(ii) 15(a) of that Part of that Schedule for all other packages, or

**b.** the tests specified in paragraphs 7 – 12 of Part IV of Schedule 9 followed by the test in paragraph 17 of Part IV of Schedule 9.

**6.** In determining the subcriticality of individual packages in isolation for the purposes of this Schedule, it must be assumed that water can leak into or out of all void spaces of the package, including those within the containment system. However, if the design incorporates special features to prevent such leakage of water into or out of certain void spaces, even as a result of human error, absence of leakage may be assumed in respect of those void spaces. Special features shall include the following—

(a) multiple high standard water barriers, each of which would remain watertight if the package were damaged; a high degree of quality control in the production and maintenance of packagings; and special tests to demonstrate the closure of each package before shipment; or

(b) for packages containing uranium hexafluoride only—

(i) where for damaged packages there is no physical contact between the valve and any other component of the packaging other than its original point of attachment and where, in addition, following the test specified in paragraph 16 of Part IV of Schedule 9 the valves remain leaktight; and

*Status: This is the original version (as it was originally made).*

- (ii) a high degree of quality control in the production and maintenance and repair of packagings; and special tests to demonstrate the closure of each package before each shipment

7. The individual package damaged or undamaged must be subcritical under the conditions specified in paragraphs 5 and 6 taking into account the physical and chemical characteristics including any change in those characteristics which could occur when the package is damaged and with the conditions of moderation and reflection as specified below.

For all material within the confinement system: the material arranged in the confinement system—

- (a) in the configuration and moderation that results in maximum neutron multiplication; and
- (b) with close reflection of the containment system by water 20 cm thick (or equivalent), or such greater reflection of the containment system as may additionally be provided by the surrounding material of the packaging unless it can be demonstrated that the confinement system remains within the damaged packaging;

8. An array of packages must be subcritical. A number, “N” must be derived assuming that if packages were stacked together in any arrangement with the stack closely reflected on all sides by water 20 cm thick (or its equivalent) both of the following conditions would be satisfied—

- (a) five times “N” undamaged packages without anything between the packages would be subcritical; and
- (b) two times “N” damaged packages with hydrogenous moderation between packages to the extent which results in the greatest neutron multiplication would be subcritical and, in addition if any part of the fissile material escapes from the containment system: that material, from two times “N” damaged packages must be subcritical when arranged in—
  - (i) the configuration and moderation that results in maximum neutron multiplication; and
  - (ii) with close reflection of that material by water 20 cm thick (or equivalent).

9. In evaluating the subcriticality of fissile material in its transport configuration, the following must apply—

- (a) the determination of subcriticality for irradiated fissile material must be based on an isotopic composition demonstrated to provide—
  - (i) the maximum neutron multiplication during the irradiation history, or
  - (ii) a conservative estimate of the neutron multiplication for the package assessments. After irradiation but prior to shipment, a measurement must be performed to confirm the conservatism of the isotopic composition; and
- (b) for fissile material whose chemical or physical form, isotopic composition, mass or concentration, moderation ratio or density, or geometric configuration is not known, each parameter that is not known must have the value which gives the maximum neutron multiplication consistent with the known conditions and parameters in paragraphs 5 to 8.

10. The package must be designed for an ambient temperature range of  $-40^{\circ}\text{C}$  to  $+38^{\circ}\text{C}$  unless the Secretary of State specifies otherwise in the certificate of approval for the package design.

## SCHEDULE 9

Regulation 51

### TEST PROCEDURES

#### PART I

##### LEACHING TEST FOR LSA-III MATERIAL AND LOW DISPERSIBLE RADIOACTIVE MATERIAL

A solid material sample representing the entire contents of the package is to be immersed for 7 days in water at ambient temperature. The volume of water to be used in the test must be sufficient to ensure that at the end of the 7-day test period, the free volume of the unabsorbed and unreacted water remaining must be at least 10% of the volume of the solid test sample itself. The water must have an initial pH of 6-8 and a maximum conductivity of 1 mS/m at 20 176 C. The total activity of the free volume of water must be measured following the 7-day immersion of the test sample.

#### PART II

##### TESTS FOR SPECIAL FORM RADIOACTIVE MATERIAL

1. The tests which must be performed on specimens that comprise or simulate special form radioactive material are: the impact test, the percussion test, the bending test and the heat test.
2. A different specimen may be used for each of the tests.
3. After each test specified in paragraphs 4 – 8 below, a leaching assessment or volumetric leakage test must be performed on the specimen by a method no less sensitive than the methods given in paragraph 9 below for indispersible solid material and paragraph 10 below for encapsulated material.
4. Impact test: The specimen must drop onto the target from a height of 9 metres. The target must be as defined in paragraph 5 of Part IV of this Schedule.
5. Percussion test: The specimen must be placed on a sheet of lead which is supported by a smooth solid surface and struck by the flat face of a mild steel bar so as to cause an impact equivalent to that resulting from a free drop of 1.4 kg through 1 metre. The lower part of the bar must be 25 mm in diameter with the edges rounded off to a radius of  $(3.0 \pm 0.3)$ mm. The lead, of hardness number 3.5 to 4.5 on the Vickers scale and not more than 25 mm thick, must cover an area greater than that covered by the specimen. A fresh surface of lead must be used for each impact. The bar must strike the specimen so as to cause maximum damage.
6. Bending test: This test applies only to long, slender sources with both a minimum length of 10 cm and a length to minimum width ratio of not less than 10. The specimen must be rigidly clamped in a horizontal position so that one half of its length protrudes from the face of the clamp. The orientation of the specimen must be such that the specimen will suffer maximum damage when its free end is struck by the flat face of a steel bar. The bar must strike the specimen so as to cause an impact equivalent to that resulting from a free vertical drop of 1.4 kg through 1 metre. The lower part of the bar must be 25 mm in diameter with the edges rounded off to a radius of  $(3.0 \pm 0.3)$ mm.
7. Heat test: The specimen must be heated in air to a temperature of 800°C and held at that temperature for a period of 10 minutes and must then be allowed to cool.
8. Specimens that comprise or simulate radioactive material enclosed in a sealed capsule may be excepted from—

*Status: This is the original version (as it was originally made).*

- (a) the tests prescribed in paragraphs 4 and 5 provided the mass of the special form radioactive material is less than 200 g and provided they are alternatively subjected to the Class 4 impact test prescribed in the ISO classification document; and
  - (b) the test prescribed in paragraph 7 provided they are alternatively subjected to the Class 6 temperature test specified in the ISO classification document.
- 9.** For specimens which comprise or simulate indispersible solid material, a leaching assessment must be performed as follows—
- (a) the specimen must be immersed for 7 days in water at ambient temperature. The volume of water to be used in the test must be sufficient to ensure that at the end of the 7-day test period the free volume of the unabsorbed and unreacted water remaining must be at least 10% of the volume of the solid test sample itself. The water must have an initial pH of 6-8 and a maximum conductivity of 1 mS/m at 20°C;
  - (b) the water with specimen must then be heated to a temperature of  $(50 \pm 5)^\circ\text{C}$  and maintained at this temperature for 4 hours;
  - (c) the activity of the water must then be determined;
  - (d) the specimen must then be stored for at least 7 days in still air at a temperature not less than 30°C and relative humidity of not less than 90%;
  - (e) the specimen must then be immersed in water of the same specification as in (a) above and the water with the specimen heated to  $(50 \pm 5)^\circ\text{C}$  and maintained at this temperature for 4 hours;
  - (f) the activity of the water must then be determined.
- 10.** For specimens which comprise or simulate radioactive material enclosed in a sealed capsule, either a leaching assessment or a volumetric leakage assessment must be performed as follows—
- (a) the leaching assessment must consist of the following steps—
    - (i) the specimen must be immersed in water at ambient temperature. The water must have an initial pH of 6-8 with a maximum conductivity of 1 mS/m at 20°C;
    - (ii) the water and specimen must be heated to a temperature of  $(50 \pm 5)^\circ\text{C}$  and maintained at this temperature for 4 hours;
    - (iii) the activity of the water must then be determined;
    - (iv) the specimen must then be stored for at least 7 days in still air at a temperature not less than 30°C and relative humidity of not less than 90%;
    - (v) the process in (i), (ii) and (iii) must be repeated;
  - (b) the alternative volumetric leakage assessment shall comprise any of the tests prescribed in the ISO leak test document which are acceptable to the Secretary of State.

## PART III

### TESTS FOR LOW DISPERSIBLE RADIOACTIVE MATERIAL

- 1.** The tests which must be performed on specimens that comprise or simulate low dispersible radioactive material are: the enhanced thermal test and the impact test.
- 2.** A different specimen may be used for each of the tests.
- 3.** After each test specified in paragraphs 4 – 5 below, a leaching assessment must be performed on the specimen according to the method set out in Part I.
- 4.** Enhanced thermal test: This test must be the test set out in paragraph 25 of Part IV.



5. Impact test: This test must be the test set out in paragraph 26 of Part IV.

## PART IV

### TESTS FOR PACKAGES

1. All specimens must be inspected before testing in order to identify and record faults or damage including the following—
  - (a) divergence from the design;
  - (b) defects in manufacture;
  - (c) corrosion or other deterioration; and
  - (d) distortion of features.
2. The containment system of the package must be clearly specified.
3. The external features of the specimen must be clearly identified so that reference may be made simply and clearly to any part of such specimen.
4. After each of the applicable tests specified in paragraphs 6 — 26 below—
  - (a) faults and damage must be identified and recorded;
  - (b) it must be determined whether the integrity of the containment system and shielding has been retained to the extent required in Schedule 8 for the package under test; and
  - (c) for packages containing fissile material, it must be determined whether the assumptions and conditions made in the assessments required by paragraphs 1 to 9 of Part XIV Schedule 8 regarding the most reactive configuration and degree of moderation of the fissile contents, of any escaped material, and for one or more packages are valid.

#### **Target for Drop Tests**

5. The target for the drop tests specified in paragraph 4 of Part II and paragraphs 10, 13(a), 15, and 24 and 26 of Part IV must be a flat, horizontal surface of such a character that any increase in its resistance to displacement or deformation upon impact by the specimen would not significantly increase the damage to the specimen.

#### **Packages Designed to contain Uranium Hexafluoride**

6. Specimens that comprise or simulate packagings designed to contain 0.1 kg or more of uranium hexafluoride must be tested hydraulically at an internal pressure of at least 1.38 MPa but, when the test pressure is less than 2.76 MPa, the design must require multilateral approval. For retesting packagings, any other equivalent non-destructive testing may be applied subject to multilateral approval.

#### **Tests for demonstrating ability to withstand normal conditions of transport**

7. The tests are: the water spray test, the free drop test, the stacking test, and the penetration test. Specimens of the package must be subjected to the free drop test, the stacking test and the penetration test, preceded in each case by the water spray test. One specimen may be used for all the tests, provided that the requirements of paragraph 8 are fulfilled.
8. The time interval between the conclusion of the water spray test and the succeeding test must be such that the water has soaked in to the maximum extent, without appreciable drying of the exterior of the specimen. In the absence of any evidence to the contrary, this interval must be taken

*Status: This is the original version (as it was originally made).*

to be two hours if the water spray is applied from four directions simultaneously. No time interval shall elapse, however, if the water spray is applied from each of the four directions consecutively.

**9.** Water spray test: The specimen must be subjected to a water spray test that simulates exposure to rainfall of approximately 5 cm per hour for at least one hour.

**10.** Free drop test: The specimen must drop on to the target so as to suffer maximum damage in respect of the safety features to be tested and—

- (a) the height of drop measured from the lowest point of the specimen to the upper surface of the target must be not less than the distance specified in Table XI of Schedule 1 for the applicable mass. The target must be as defined in paragraph 5 above;
- (b) for rectangular fibreboard or wood packages not exceeding a mass of 50 kg, a separate specimen must be subjected to a free drop on to each corner from a height of 0.3 metres;
- (c) for cylindrical fibreboard packages not exceeding a mass of 100 kg, a separate specimen must be subjected to a free drop on to each of the quarters of each rim from a height of 0.3 metres.

**11.** Stacking test: Unless the shape of the packaging effectively prevents stacking, the specimen must be subjected, for a period of 24 hours, to a compressive load equal to the greater of the following—

- (a) the equivalent of 5 times the mass of the actual package; and
- (b) the equivalent of 13 kPa multiplied by the vertically projected area of the package.

The load must be applied uniformly to two opposite sides of the specimen, one of which must be the base on which the package would normally rest.

**12.** Penetration test: The specimen must be placed on a rigid, flat, horizontal surface which will not move significantly while the test is carried out—

- (a) a bar of 3.2 cm in diameter with a hemispherical end and a mass of 6 kg must be dropped and directed to fall, with its longitudinal axis vertical, on to the centre of the weakest part of the specimen, so that, if it penetrates sufficiently far, it will hit the containment system. The bar must not be significantly deformed by the test performance;
- (b) the height of drop of the bar measured from its lower end to the intended point of impact on the upper surface of the specimen must be 1 metre.

#### **Tests for Type A packages designed to carry liquids and gases**

**13.** A specimen or separate specimens must be subjected to each of the following tests unless it can be demonstrated that one test is more severe for the specimen in question than the other, in which case one specimen must be subjected to the more severe test—

- (a) free drop test: The specimen must drop on to the target so as to suffer the maximum damage in respect of containment. The height of the drop measured from the lowest part of the specimen to the upper surface of the target must be 9 metres. The target must be as defined in paragraph 5 above;
- (b) penetration test: The specimen must be subjected to the test specified in paragraph 12 above except that the height of drop must be increased to 1.7 metres from the 1 metre specified in paragraph 12(b).

#### **Tests for demonstrating ability to withstand accident conditions of transport**

**14.** The specimen must be subjected to the cumulative effects of the tests specified in paragraphs 15 and 16, in that order. Following these tests, either this specimen or a separate specimen must

be subjected to the effect(s) of the water immersion test(s) as specified in paragraph 17 and, if applicable, paragraph 18.

**15. Mechanical test:** The mechanical test consists of three different drop tests. Each specimen must be subjected to the applicable drops as specified in paragraph 7 of Part XI of Schedule 8 or paragraphs 5 and 8 of Part XIV of Schedule 8. The order in which the specimen is subjected to the drops must be such that, on completion of the mechanical test, the specimen must have suffered such damage as will lead to the maximum damage in the thermal test which follows—

- (a) for drop I, the specimen must drop on to the target so as to suffer the maximum damage, and the height of the drop measured from the lowest point of the specimen to the upper surface of the target must be 9 metres. The target must be as defined in paragraph 5 above;
- (b) for drop II, the specimen must drop so as to suffer the maximum damage on to a bar rigidly mounted perpendicularly on the target. The height of the drop measured from the intended point of impact of the specimen to the upper surface of the bar must be 1 metre. The bar must be of solid mild steel of circular section,  $(15.0 \pm 0.5)$ cm in diameter, and 20 cm long unless a longer bar would cause greater damage, in which case a bar of sufficient length to cause maximum damage must be used. The upper end of the bar must be flat and horizontal with its edges rounded off to a radius of not more than 6 mm. The target on which the bar is mounted must be as described in paragraph 5;
- (c) for drop III, the specimen must be subjected to a dynamic crush test by positioning the specimen on the target so as to suffer maximum damage by the drop of a 500 kg mass from 9 metres on to the specimen. The mass must consist of a solid mild steel plate 1 metre  $\times$  1 metre which must fall in a horizontal attitude. The height of the drop must be measured from the underside of the plate to the highest point of the specimen. The target on which the specimen rests must be as defined in paragraph 5.

**16. Thermal test:** The thermal test must consist of—

- (a) the specimen must be in thermal equilibrium under the conditions of ambient temperature of 38°C, subject to the solar insolation conditions specified in Table IX of Schedule I and subject to the design maximum rate of internal heat generation from the radioactive contents. Alternatively, any of these parameters are allowed to have different values prior to and during the test, providing due account is taken of them in the subsequent assessment of package response, followed by;
- (b) the exposure of a specimen to a thermal environment which provides a heat flux at least equal to that of a hydrocarbon fuel/air fire in sufficiently quiescent ambient conditions to give an average emissivity coefficient of at least 0.9 and an average flame temperature of at least 800°C fully engulfing the specimen for a period of 30 minutes, with a surface absorptivity coefficient of either 0.8 or that value which the package may be demonstrated to possess if exposed to the fire specified, followed by;
- (c) exposure of the specimen to an ambient temperature of 38°C, subject to the solar insolation conditions specified in Table IX of Schedule I and subject to the design maximum rate of heat generation from the radioactive contents for a sufficient period to ensure that temperatures in the specimen are everywhere decreasing and/or are approaching steady state conditions. Alternatively, any of these parameters are allowed to have different values following cessation of heating, providing due account is taken of them in the subsequent assessment of package response.

During and following the test the specimen must not be artificially cooled and any combustion of materials of the specimen must be permitted to proceed naturally.

**17. Water immersion test:** The specimen must be immersed under a head of water of at least 15 metres for a period of not less than eight hours in the attitude which will lead to maximum damage.

For demonstration purposes, an external gauge pressure of at least 150 kPa must be considered to meet these conditions.

#### **Enhanced water immersion test**

**18.** The specimen must be immersed under a head of water of at least 200 metres for a period of not less than one hour. For demonstration purposes, an external gauge pressure of at least 2 MPa must be considered to meet these conditions.

#### **Water leakage test for packages containing fissile material**

**19.** Packages for which water in-leakage or out-leakage to the extent which results in greatest reactivity has been assumed for purposes of assessment under paragraphs 5 to 8 of Part XIV of Schedule 8 shall be excepted from the test specified in paragraph 21.

**20.** Before the specimen is subjected to the water leakage test specified in paragraph 21, it must be subjected to the tests in paragraph 15(b), and either paragraph 15(a) or (c), and the test specified in paragraph 16.

**21.** The specimen must be immersed under a head of water of at least 0.9 metres for a period of not less than eight hours and in the attitude for which maximum leakage is expected.

#### **Tests for Type C packages**

**22.** Specimens must be subjected to the effects of each of the following test sequences in the orders specified—

- (a) the tests specified in paragraphs 15(a), 15(c), 24 and 25; and
- (b) the test specified in paragraph 26.

**23.** Separate specimens are allowed to be used for each of the sequences 22 (a) and (b).

**24.** Puncture/tearing test: The specimen must be subjected to the damaging effects of a solid probe made of mild steel. The orientation of the probe to the surface of the specimen must be as to cause maximum damage at the conclusion of the test sequence specified in paragraph 22(a)—

- (a) The specimen, representing a package having a mass less than 250 kg, must be placed on a target and subjected to a probe having a mass of 250 kg falling from a height of 3 m above the intended impact point. For this test, the probe must be a 20 cm diameter cylindrical bar with the striking end forming a frustum of a right circular cone with the following dimensions: 30 cm height and 2.5 cm in diameter at the top. The target on which the specimen is placed must be as specified in paragraph 5.
- (b) For packages having a mass of 250 kg or more, the base of the probe must be placed on a target and the specimen dropped onto the probe. The height of the drop, measured from the point of impact with the specimen to the upper surface of the probe must be 3 m. For this test the probe must have the same properties and dimensions as specified in (a) above, except that the length and mass of the probe must be such as to incur maximum damage to the specimen. The target on which the base of the probe is placed must be as specified in paragraph 5.

**25.** Enhanced thermal test: The conditions for this test are as specified in paragraph 16, except that the exposure to the thermal environment must be for a period of 60 minutes.

**26.** Impact test: The specimen must be subjected to an impact on a target at a velocity of not less than 90 m/s, at such an orientation as to suffer maximum damage. The target must be as defined in paragraph 5.

## PART V

### DEMONSTRATION OF COMPLIANCE

Demonstration of compliance with the performance standards required by Schedule 8 shall be accomplished by any of the following methods or by a combination thereof—

1. Performance of tests with specimens or prototypes or samples of the packaging simulating as closely as practicable the expected range of radioactive contents, and with the specimen or packaging to be tested prepared as normally presented for transport.
2. Reference to previous satisfactory demonstrations of a sufficiently similar nature.
3. Performance of tests with models of appropriate scale incorporating those features which are significant with respect to the item under investigation when engineering experience has shown results of such tests to be suitable for design purposes. When a scale model is used, the need for adjusting certain test parameters, such as penetrator diameter or compressive load, must be taken into account.
4. Calculation, or reasoned argument, when the calculation procedures and parameters are agreed by the Secretary of State to be reliable or conservative.
5. After the specimen, prototype or sample has been subjected to the tests, appropriate methods of assessment must be used to ensure that the requirements of this section have been fulfilled in compliance with the performance and acceptance standards prescribed in Schedule 8.

#### SCHEDULE 10

Regulations 54(2), 56(3), 57(2)(b), 58(2),  
60(2) and 61(2)

### APPLICATION REQUIREMENTS

## PART I

### APPLICATION FOR APPROVAL OF DESIGN FOR SPECIAL FORM RADIOACTIVE MATERIAL OR LOW DISPERSIBLE RADIOACTIVE MATERIAL

An application for approval must include the following—

1. A detailed description of the radioactive material or, if a capsule, the contents. Particular reference must be made to both physical and chemical states.
2. A detailed statement of the design of any capsule to be used.
3. A statement of the tests which have been done and their results, or evidence based on calculative methods to show that the radioactive material is capable of meeting the performance standards, or other evidence that the special form radioactive material or low dispersible radioactive material meets the applicable requirements of these Regulations.
4. Evidence of a suitable quality assurance programme.
5. Any proposed pre-shipment actions for use in the consignment of special form radioactive material or low dispersible radioactive material.

## PART II

### APPLICATION FOR PACKAGE DESIGN APPROVAL CERTIFICATE FOR A TYPE B(U) OR TYPE C PACKAGE

An application for a package design approval certificate for a Type B(U) package must include the following—

1. A detailed description of the proposed radioactive contents with reference to their physical and chemical states and the nature of the radiation emitted.
2. A detailed statement of the design, including complete engineering drawings and schedules of materials and methods of manufacture to be used.
3. A statement of the tests which have been done and their results, or evidence based on calculative methods or other evidence that the design is adequate to meet the applicable requirements of these Regulations.
4. The proposed operating and maintenance instructions for the use of the packaging.
5. If the package is designed to have a maximum normal operating pressure in excess of 100 kPa gauge, a specification of the materials of manufacture of the containment system, the samples to be taken, and the tests to be made.
6. Where the proposed radioactive contents are irradiated fuel, the applicant must state and justify any assumption in the safety analysis relating to the characteristics of the fuel and describe any pre-shipment measurement required by paragraph 9(a)(ii) of Part XIV of Schedule 8.
7. Any special stowage provisions necessary to ensure the safe dissipation of heat from the package; considering the various modes of transport to be used and type of conveyance or freight container.
8. A reproducible illustration not larger than 21 cm × 30 cm showing the make-up of the package.
9. A specification of the applicable quality assurance programme.
10. Evidence of a suitable emergency plan.

## PART III

### APPLICATION FOR PACKAGE DESIGN APPROVAL CERTIFICATE FOR A TYPE B(M) PACKAGE

An application for a package design approval certificate for a Type B(M) package design must include the following—

1. The information required in Part II for Type B(U) or Type C packages.
2. A list of the requirements specified in paragraph 5 of Part X of Schedule 8, paragraph 4, 5 and 8-15 of Part XI of Schedule 8, with which the package does not conform.
3. Any proposed supplementary operational controls to be applied during transport not regularly provided for in these Regulations, but which are necessary to ensure the safety of the package or to compensate for the deficiencies listed in paragraph 2 above.
4. A statement relative to any restrictions on the mode of transport and to any special loading, carriage, unloading or handling procedures.
5. The maximum and minimum ambient conditions (temperature, solar radiation) expected to be encountered during transport and which have been taken into account in the design.

## PART IV

### APPLICATION FOR PACKAGE DESIGN APPROVAL CERTIFICATE FOR FISSILE MATERIAL

An application for a package design approval certificate for fissile material must include the following—

1. All information necessary to satisfy the Secretary of State that the package design meets the requirements of Part XIV of Schedule 8, as applicable, taking into account the nature, activity and form of the contents.
2. A specification of the applicable quality assurance programme.

## PART V

### APPLICATION FOR A SHIPMENT APPROVAL CERTIFICATE

An application for a shipment approval certificate must include—

1. The period of time, related to the shipment, for which the approval is sought.
2. The actual radioactive contents, the expected modes of transport and the type of conveyance and the probable, or proposed route.
3. The details of how the precautions and administrative or operational controls, referred to in the package design approval certificates are to be put into effect.
4. Evidence of a suitable emergency plan.

## PART VI

### APPLICATION FOR A SPECIAL ARRANGEMENT APPROVAL CERTIFICATE

An application for approval of shipments under special arrangement must include—

1. All the information necessary to satisfy the competent authority that the overall level of safety in transport is at least equivalent to that which would be provided if all the applicable requirements of these Regulations had been met.
2. A statement of the respects in which, and justification of why, the transport of the consignment cannot be made in full accordance with the applicable requirements.
3. A statement of any special precautions or special administrative or operational controls which are to be employed during transport to compensate for the failure to meet the applicable requirements.
4. Evidence of a suitable emergency plan.

## SCHEDULE 11

Regulation 23

### DETERMINATION OF CATEGORIES

Packages and overpacks must be assigned to either category I-WHITE, II-YELLOW or III-YELLOW in accordance with the conditions specified in Table VII of Schedule 1 and with the following requirements—

*Status: This is the original version (as it was originally made).*

- (a) For a package or overpack, both the Transport Index (TI) and the surface radiation level conditions must be taken into account in determining which is the appropriate category. Where the Transport Index (TI) satisfies the condition for one category but the surface radiation level satisfies the condition for a different category, the package or overpack must be assigned to the higher category of the two. For this purpose, category I-WHITE must be regarded as the lowest category.
- (b) The Transport Index (TI) must be determined following the procedures specified in regulation 44.
- (c) If the surface radiation level is greater than 2 mSv/h, the package or overpack must be transported under exclusive use and in accordance with the conditions prescribed in paragraph 8(a) of Schedule 7.
- (d) A package transported under special arrangement must be assigned to category III-YELLOW.
- (e) An overpack which contains packages transported under special arrangement must be assigned to category III-YELLOW.

## SCHEDULE 12

Regulation 64

### CONTENTS OF APPROVAL CERTIFICATES.

## PART I

### SPECIAL FORM RADIOACTIVE MATERIAL AND LOW DISPERSIBLE RADIOACTIVE MATERIAL APPROVAL CERTIFICATES

Each approval certificate issued by the Secretary of State for special form radioactive material or low dispersible radioactive material should include the following information—

- (a) Type of certificate.
- (b) The Secretary of State identification mark.
- (c) The issue date and an expiry date.
- (d) List of applicable national and international regulations, including the edition of the IAEA Regulations for the Safe Transport of Radioactive Material under which the special form radioactive material or low dispersible radioactive material is approved.
- (e) The identification of the special form radioactive material or low dispersible radioactive material.
- (f) A description of the special form radioactive material or low dispersible radioactive material.
- (g) Design specifications for the special form radioactive material or low dispersible radioactive material which may include references to drawings.
- (h) A specification of the radioactive contents which includes the activities involved and which may include the physical and chemical form.
- (i) A specification of the applicable quality assurance programme as required in regulation 18.
- (j) Reference to information provided by the applicant relating to specific actions to be taken prior to shipment.
- (k) If deemed appropriate by the Secretary of State, reference to the identity of the applicant.



- (l) Signature and identification of the certifying official.

## PART II

### SPECIAL ARRANGEMENT APPROVAL CERTIFICATES

Each approval certificate issued by the Secretary of State for a special arrangement must include the following information—

- (a) Type of certificate.
- (b) The Secretary of State identification mark.
- (c) The issue date and an expiry date.
- (d) Mode of transport.
- (e) Any restrictions on the modes of transport, type of conveyance, freight container, and any necessary routing instructions.
- (f) List of applicable national and international regulations, including the edition of the IAEA Regulations for the Safe Transport of Radioactive Material under which the special arrangement is approved.
- (g) The following statement:
  - “This certificate does not relieve the consignor from compliance with any requirement of the government of any country through or into which the package will be transported.”
- (h) References to certificates for alternative radioactive contents, other competent authority validation, or additional technical data or information, as deemed appropriate by the Secretary of State.
- (i) Description of the packaging by a reference to the drawings or a specification of the design. If deemed appropriate by the Secretary of State, a reproducible illustration, not larger than 21 cm by 30 cm, showing the make-up of the package may also be included, accompanied by a brief description of the packaging, including materials of manufacture, gross mass, general outside dimensions and appearance.
- (j) A specification of the authorised radioactive contents, including any restrictions on the radioactive contents which might not be obvious from the nature of the packaging. This must include the physical and chemical forms, the activities involved (including those of the various isotopes, if appropriate), amounts in grams (for fissile material), and whether special form radioactive material or low dispersible radioactive material, if applicable.
- (k) Additionally, for packages containing fissile material—
  - (i) a detailed description of the authorised radioactive contents;
  - (ii) the value of the criticality safety index;
  - (iii) reference to the documentation that demonstrates the criticality safety of the contents;
  - (iv) any special features, on the basis of which the absence of water from certain void spaces has been assumed in the criticality assessment;
  - (v) any allowance (based on paragraph 9 of Part XIV of Schedule 8) for a change in neutron multiplication assumed in the criticality assessment as a result of actual irradiation experience; and
  - (vi) the ambient temperature range for which the special arrangement has been approved.

*Status: This is the original version (as it was originally made).*

- (l) A detailed listing of any supplementary operational controls required for preparation, loading, carriage, unloading and handling of the consignment, including any special stowage provisions for the safe dissipation of heat.
- (m) If deemed appropriate by the Secretary of State, reasons for the special arrangement.
- (n) Description of the compensatory measures to be applied as a result of the shipment being under special arrangement.
- (o) Reference to information provided by the applicant relating to the use of the packaging or specific actions to be taken prior to the shipment.
- (p) A statement regarding the ambient conditions assumed for purposes of design if these are not in accordance with those specified in paragraphs 4,5 and 15 of Part XI of Schedule 8, as applicable.
- (q) Any emergency arrangements deemed necessary by the Secretary of State.
- (r) A specification of the applicable quality assurance programme as required in regulation 18.
- (s) If deemed appropriate by the Secretary of State, reference to the identity of the applicant and to the identity of the carrier.
- (t) Signature and identification of the certifying official.

### PART III

#### SHIPMENT APPROVAL CERTIFICATES

Each approval certificate for a shipment issued by the Secretary of State must include the following information—

- (a) Type of certificate.
- (b) The Secretary of State identification mark.
- (c) The issue date and an expiry date.
- (d) List of applicable national and international regulations, including the edition of the IAEA Regulations for the Safe Transport of Radioactive Material under which the shipment is approved.
- (e) Any restrictions on the modes of transport, type of conveyance, freight container, and any necessary routeing instructions.
- (f) The following statement;
  - “This certificate does not relieve the consignor from compliance with any requirement of the government of any country through or into which the package will be transported.”
- (g) A detailed listing of any supplementary operational controls required for preparation, loading, carriage, unloading and handling of the consignment, including any special stowage provisions for the safe dissipation of heat or maintenance of criticality safety.
- (h) Reference to information provided by the applicant relating to specific actions to be taken prior to shipment.
- (i) Reference to the applicable design approval certificate.
- (j) A specification of the actual radioactive contents, including any restrictions on the radioactive contents which might not be obvious from the nature of the packaging. This must include the physical and chemical forms, the total activities involved (including those of the various isotopes, if appropriate), amounts in grams (for fissile material), and whether special form radioactive material or low dispersible radioactive material, if applicable.

- (k) Any emergency arrangements deemed necessary by the Secretary of State.
- (l) A specification of the applicable quality assurance programme as required in regulation 18.
- (m) If deemed appropriate by the Secretary of State, reference to the identity of the applicant.
- (n) Signature and identification of the certifying official.

## PART IV

### PACKAGE DESIGN APPROVAL CERTIFICATES

Each approval certificate of the design of a package issued by the Secretary of State must include the following information—

- (a) Type of certificate.
- (b) The Secretary of State identification mark.
- (c) The issue date and an expiry date.
- (d) Any restriction on the modes of transport, if appropriate.
- (e) List of applicable national and international regulations, including the edition of the IAEA Regulations for the Safe Transport of Radioactive Material under which the design is approved.
- (f) The following statement;
  - “This certificate does not relieve the consignor from compliance with any requirement of the government of any country through or into which the package will be transported.”
- (g) References to certificates for alternative radioactive contents, other competent authority validation, or additional technical data or information, as deemed appropriate by the Secretary of State.
- (h) Identification of the packaging.
- (i) Description of the packaging by a reference to the drawings or specification of the design. If deemed appropriate by the Secretary of State, a reproducible illustration, not larger than 21 cm by 30 cm, showing the make-up of the package may also be included, accompanied by a brief description of the packaging, including materials of manufacture, gross mass, general outside dimensions and appearance.
- (j) Specification of the design by reference to the drawings.
- (k) A specification of the authorised radioactive content, including any restrictions on the radioactive contents which might not be obvious from the nature of the packaging. This must include the physical and chemical forms, the activities involved (including those of the various isotopes, if appropriate), amounts in grams (for fissile material), and whether special form radioactive material or low dispersible radioactive material, if applicable.
- (l) Additionally, for packages containing fissile material—
  - (i) a detailed description of the authorised radioactive contents;
  - (ii) the value of the criticality safety index;
  - (iii) reference to the documentation that demonstrates the criticality safety of the contents;
  - (iv) any special features, on the basis of which the absence of water from certain void spaces has been assumed in the criticality assessment;

*Status: This is the original version (as it was originally made).*

- (v) any allowance (based on paragraph 9 of Part XIV of Schedule 8) for a change in neutron multiplication assumed in the criticality assessment as a result of actual irradiation experience; and
- (vi) the ambient temperature range for which the package design has been approved.
- (m) For Type B(M) packages, a statement specifying those prescriptions of paragraph 5 of Part X of Schedule 8 and paragraphs 4, 5 and 8 to 15 of Part XI of Schedule 8 with which the package does not conform and any amplifying information which may be useful to other competent authorities.
- (n) A detailed listing of any supplementary operational controls required for preparation, loading, carriage, unloading and handling of the consignment, including any special stowage provisions for the safe dissipation of heat.
- (o) Reference to information provided by the applicant relating to the use of the packaging or specific actions to be taken prior to shipment.
- (p) A statement regarding the ambient conditions assumed for purposes of design if these are not in accordance with those specified in paragraphs 4, 5 and 15 of Part XI of Schedule 8, as applicable.
- (q) A specification of the applicable quality assurance programme as required in regulation 18.
- (r) Any emergency arrangements deemed necessary by the Secretary of State.
- (s) If deemed appropriate by the Secretary of State, reference to the identity of the applicant.
- (t) Signature and identification of the certifying official.

## PART V

### COMBINED PACKAGE DESIGN APPROVAL AND SHIPMENT APPROVAL CERTIFICATES.

As for Part IV and also a statement authorising shipment where shipment approval is required under regulation 60, if deemed appropriate.

#### SCHEDULE 13

Regulation 75

#### CONTENTS OF REGULAR CONSIGNMENT CERTIFICATE

A regular consignment certificate must include the following:

1. A statement that the certificate is a regular consignment certificate.
2. The issue date.
3. The information listed in paragraph 17 of Schedule 6 with the exception of paragraph (c) of that Schedule, relating to the package at the date the certificate is issued.

SCHEDULE 14

Regulations 6, 15, 21, 36, 42, 48

FIGURES

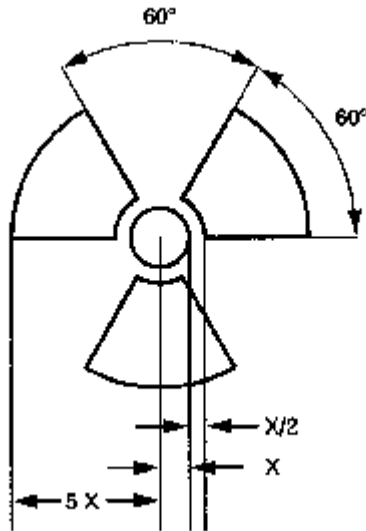

Fig. 1. Basic trefoil symbol with proportions based on a central circle of radius  $X$ . The minimum allowable size of  $X$  must be 4 mm.

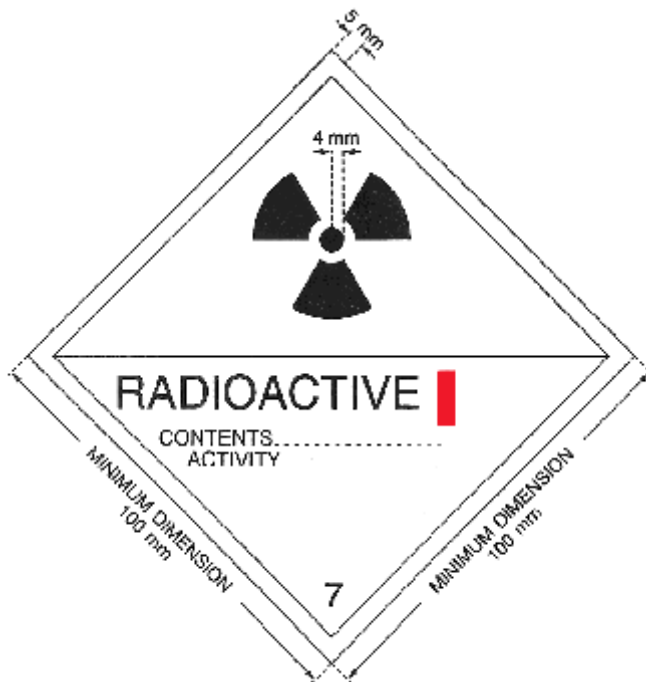

Fig. 2. Category I-WHITE label. The background colour of the label must be white, the colour of the trefoil and the printing must be black, and the colour of the category bar must be red.

Status: This is the original version (as it was originally made).

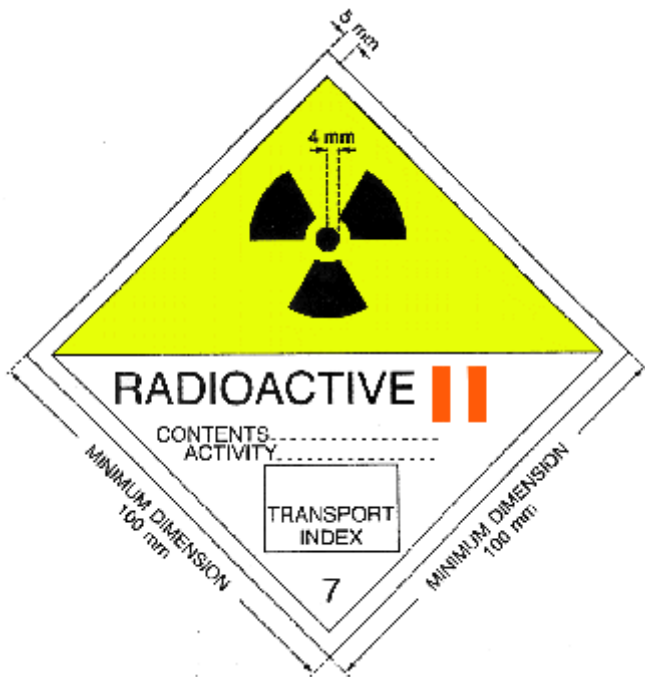

Fig. 3. Category II-YELLOW label. The background colour of the upper half of the label must be yellow and the lower half white, the colour of the trefoil and the printing must be black, and the colour of the category bars must be red.

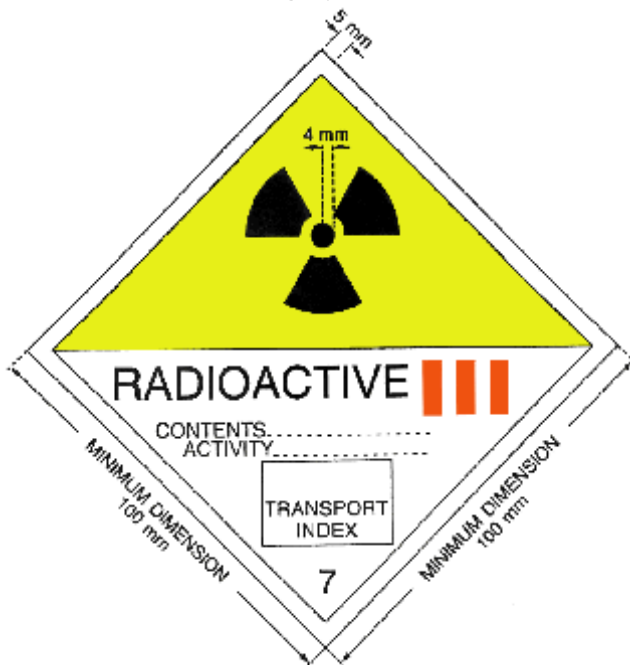

Fig. 4. Category III-YELLOW label. The background colour of the upper half of the label must be yellow and the lower half white, the colour of the trefoil and the printing must be black, and the colour of the category bars must be red.

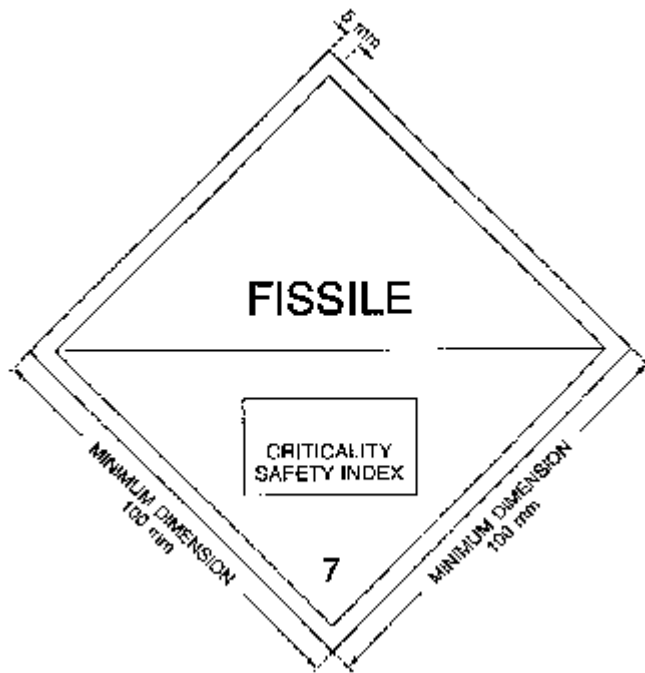

Fig. 5. Criticality safety index label. The background colour of the label must be white, the colour of the printing must be black.

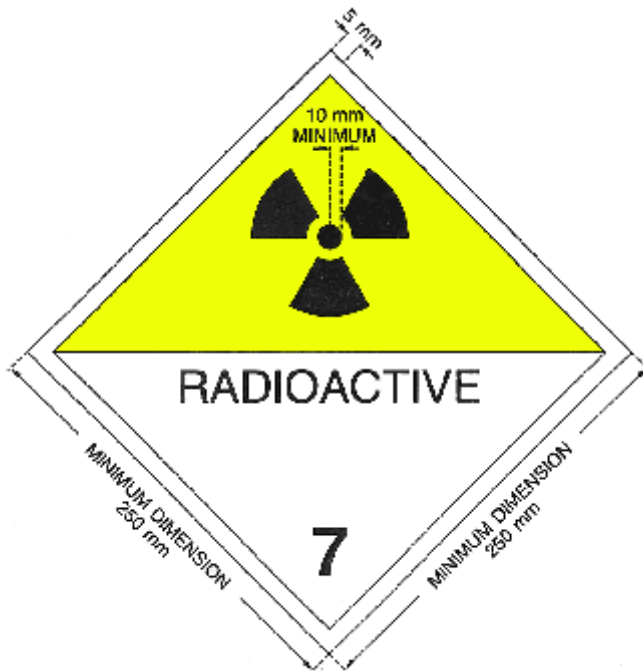

Fig. 6. Placard. Except as permitted by paragraph 15 of Schedule 6 the minimum dimensions must be as shown; when different dimensions are used the relative proportions must be maintained. The number '7' must not be less than 25 mm high. The background colour of the upper half of the placard must be yellow and of the lower half white, the colour of the trefoil and the printing must be black. The use of the word "RADIOACTIVE" in the bottom half is

**optional to allow the alternative use of this placard to display the appropriate United Nations number for the consignment.**

---

## EXPLANATORY NOTE

*(This note is not part of the Regulations)*

1. These Regulations implement regulations made by the International Atomic Energy Agency (“IAEA”) in its safety standards series for the Safe Transport of Radioactive Material (1996 Edition, No. TS-R-1) and additional requirements contained in the European Agreement concerning the international carriage of dangerous goods by road (ADR) as amended up to 1 July 2001. The Regulations also implement as respects Great Britain provisions of Council Directive 96/29/EURATOM (OJ No. L159, 29.6.96, p.1) and Commission Directive 2001/7/EC (OJ L30, 1.2.01, p.43).

2. The Regulations revoke the Radioactive Material (Road Transport) (Great Britain) Regulations 1996 (SI 1996/1350) which had implemented earlier IAEA Regulations made in 1985.

3. The Regulations are divided into 14 Parts and broadly follow the sequence of the IAEA Regulations of 1996. They make provisions concerning the transport in Great Britain of radioactive material (as defined in section 1(1) of the Radioactive Material (Road Transport) Act 1991 (c. 27) and as now amended by regulation 2 of the Radioactive Material (Road Transport) (Definition of Radioactive Material) Order 2002 (SI 2002/1092).

4. The Regulations—

- (a) in Part I, deal with commencement and application and include general provisions relating to derogation, enforcement and revocation (regulations 1 to 8);
- (b) in Part II, contain revised saving and transitory arrangements so that special form radioactive material approved under the IAEA Regulations of 1973 to 1990 may continue to be manufactured and used until 31 December 2003 but with quality assurance requirements meeting those in the IAEA Regulations of 1996 (regulations 9 to 13);
- (c) In Part III, set out general provisions dealing with prohibitions and duties involved in the transport of consignments of radioactive material (regulations 14 to 23);
- (d) in Part IV, provide provisions relating to radiation protection and to safety programmes and information to be provided to the public about health protection measures (regulations 24 to 27);
- (e) in Part V, introduce revised  $A_1$  and  $A_2$  values, radionuclide dependent material specific activity exemption limits and consignment activity limits (regulations 28 to 30);
- (f) in Part VI, impose various requirements and controls that must be fulfilled before the making of different kinds of shipments and that have to be met during the transport of radioactive materials (regulations 31 to 46);
- (g) in Part VII and Schedule 6, set out the various responsibilities of consignors and carriers (regulations 47 to 49);
- (h) in Part VIII and Schedule 8, set out the requirements that are applicable in relation to various types of radioactive material and packagings and packages (regulation 50);



- (i) in Part IX and Schedule 9, set out the tests required to be carried out on various materials and in relation to certain matters (regulation 51);
  - (j) in Part X, deal with approvals required for designs and shipments (regulations 52 to 61);
  - (k) in Part XI, contain provisions dealing with approval certificates issued by the Secretary of State (regulation 62 to 65);
  - (l) in Part XII, introduce provisions dealing with the various duties that arise upon the occurrence of a radiological emergency and the powers of inspectors and the Secretary of State (regulations 66 to 71)
  - (m) in Part XIII, deal with miscellaneous matters (regulations 72 to 75).
5. Copies of relevant documents listed below may be obtained from the Stationary Office:—
- (a) The European Agreement concerning the International Carriage of Dangerous Goods by Road (“ADR”) [ISBN 92-1-139069-9], (2001 edition).
  - (b) The United Nations Recommendations on the Transport of Dangerous Goods [92-1-139074-5], (Twelfth revised edition).
  - (c) The Regulations for the Safe Transport of Radioactive Material, (1996 Edition (Revised)) published by the International Atomic Energy Agency, Vienna 2000, TS-R-1 (ST-1, Revised) [ISBN 92-0-100500-8].
  - (d) The International Organisation for Standardisation Document, Sealed Radioactive Sources-Classification, (Reference No. ISO 2919-1980 (E)0, may be obtained from the British Standards Institution, the Sales Department, 389, Chiswick High Road, London, W4 4AL (Tel: 020 8996 9001);
  - (e) The International Organisation for Standardisation Document, Series 1 Freight Containers – Specifications and Testing – Part 1: General Cargo Containers, (Reference No. ISO 1496:1-1990(E)) may be obtained from the British Standards Institution, the Sales Department, 389, Chiswick High Road, London, W4 4AL (Tel: 020 8996 9001);
  - (f) The International Organisation for Standardisation Document, Radiation Protection – Sealed Radioactive Sources – Leak Test Methods, (Reference No. ISO 9978:1992 (E)) may be obtained from the British Standards Institution, the Sales Department, 389, Chiswick High Road, London, W4 4AL (Tel: 020 8996 9001);
  - (g) The International Organisation for Standardisation Document, Packaging of uranium hexafluoride (UF<sub>6</sub>) for transport, (Reference No. ISO 7195:1993(E)) may be obtained from the British Standards Institution, the Sales Department, 389, Chiswick High Road, London, W4 4AL (Tel: 020 8996 9001);
  - (h) The Regulations for the Safe Transport of Radioactive Material, (1973 edition) published by the International Atomic Energy Agency, Vienna 1973, Safety Series No. 6 [STI/PUB 323].
  - (i) The Regulations for the Safe Transport of Radioactive Material, (1973 edition as amended) published by the International Atomic Energy Agency, Vienna 1979, Safety Series No. 6 [ISBN 92-0-623179-0].
  - (j) The Regulations for the Safe Transport of Radioactive Material, (1985 edition) published by the International Atomic Energy Agency, Vienna 1985, Safety Series No. 6 [ISBN 92-0-123185-7].
  - (k) The Regulations for the Safe Transport of Radioactive Material, (1985 edition) (as amended 1990) published by the International Atomic Energy Agency, Vienna 1990, Safety Series No. 6 [ISBN 92-0-123890-8].
6. A Regulatory Impact Assessment has been prepared and copies can be obtained from the Department of Transport, Local Government and the Regions, Radioactive Materials Transport

**Status:** This is the original version (as it was originally made).

Division, 76 Marsham Street, London SW1P 4DR (telephone 020 7944 5768) and copies are to be placed in the libraries of each House of Parliament

7. A Transposition Note, showing how the Regulations give effect to the Commission and Council Directives may also be obtained from the Department of Transport, Local Government and the Regions, Radioactive Materials Transport Division, 76 Marsham Street, London SW1P 4DR (telephone 020 7944 5768) and copies are to be placed in the libraries of each House of Parliament.